



PER4MER 3000
NON-CONTACT PREALIGNER



**NON-CONTACT PREALIGNER
MODEL PER4MER 3000**

OPERATIONS MANUAL

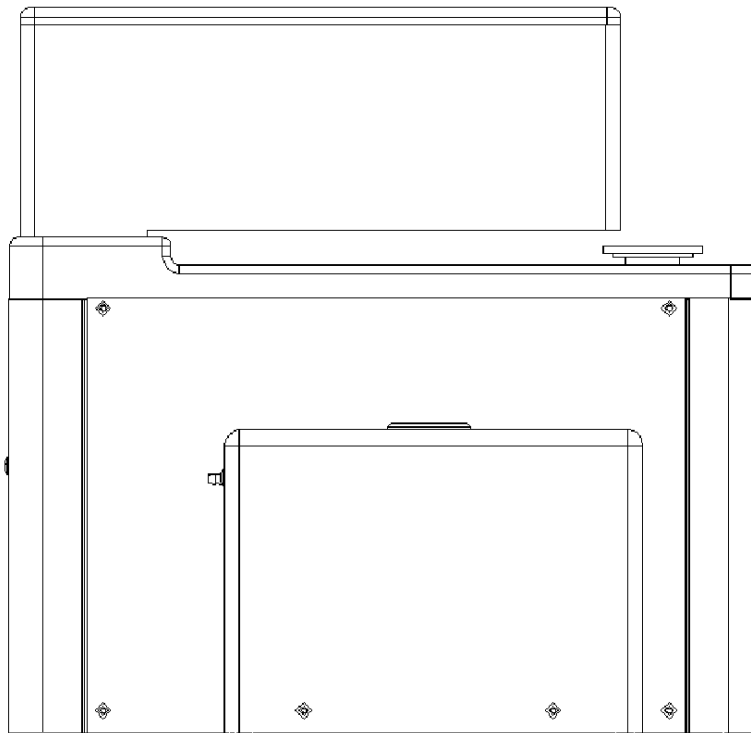

CYBEQ PART NUMBER 0123-9066

Rev B
June 12, 1999

Cybeq Systems
535 Oakmead Parkway
Sunnyvale, California 94086

Telephone: 408-328-3400
Fax: 408-328-3455

CYBEQ MODEL PER4MER 3000

CYBEQ SYSTEMS warrants to the original purchaser (Buyer) that Equipment is free from defects in material and workmanship under normal use and service in accordance with CYBEQ instructions and specifications.

Buyer shall promptly notify CYBEQ of any claim against this warranty, and any item to be returned to CYBEQ shall be sent with transportation charges prepaid by Buyer, clearly marked with a Return Material Authorization (RMA) number obtained from CYBEQ.

CYBEQ SYSTEMS' obligation under this warranty is limited to the repair or replacement, at CYBEQ's option, of any equipment, component or part, which is determined by CYBEQ to be defective in material or workmanship. This obligation shall expire 1 year after initial shipment of the Equipment from CYBEQ.

This warranty shall be void if:

Any failure is due to the misuse, neglect, improper installation of, or accident to the Equipment.

Any major repairs or alterations are made to Equipment by anyone other than a duly authorized representative of CYBEQ. Representatives of Buyer will be authorized to make repairs to Equipment without voiding warranty, on completion of the CYBEQ training program.

Replacement parts are used other than those made or recommended by CYBEQ.

CYBEQ MAKES NO OTHER WARRANTIES, EXPRESSED OR IMPLIED, WITH RESPECT TO EQUIPMENT. NO WARRANTY IS MADE AS TO THE MERCHANTABILITY OF THE EQUIPMENT TO ITS FITNESS FOR ANY PARTICULAR PURPOSE. In no event shall CYBEQ be liable for consequential loss or damages, however caused. No person or representative of CYBEQ is authorized to assume for CYBEQ any liability in connection with Equipment or to make any change to this warranty unless such change or modification is put in writing and approved by any Officer of CYBEQ.

The laws of the State of California shall govern this warranty.

TABLE of CONTENTS

1. INTRODUCTION	
1.1 NON-CONTACT PREALIGNER	1-1
2. INSTALLATION	
2.1 PACKAGING	2-1
2.2 DISASSEMBLY OF CRATE	2-2
2.3 SYSTEM INSTALLATION	2-3
3. SPECIFICATIONS	3-1
4. OPERATION	
4.1 THEORY OF OPERATION	4-1
4.2 POWER UP	4-2
4.3 COMMUNICATIONS	4-3
4.4 STANDARD DIP SWITCH SETTINGS	4-5
4.5 TEST OPERATION	4-6
4.6 NOTCH/FLAT FINDING	4-7
4.7 WAFER DIAMETER SETTING	4-8
4.8 ACTION COMMANDS	4-8
4.9 STATUS REQUESTS and RESPONSES	4-17
4.10 DIP SWITCH SETTINGS and CONFIGURATION	4-19
4.11 CONTROLLER BOARD LED	4-20
4.12 COMMAND SUMMARY	4-21
5.0 ELECTRONICS GENERAL DESCRIPTION	
5.1 SYSTEMS ARCHITECTURE	5-1
5.2 ELECTRICAL INTERFACE CONNECTIONS	5-4
5.3 PREALIGNER UNIT ELECTRONICS	5-4
5.4 DIP SWITCHES	5-5
5.5 FUSES / FAN	5-5
6.0 MECHANICAL MAINTENANCE	
6.1 PRECAUTIONS	6-1
6.2 PERIODIC MAINTENANCE	6-1
7.0 CALIBRATION/ADJUSTMENT PROCEDURES	
7.1 CD CALIBRATION	7-1
7.2 VACUUM SENSOR ADJUSTMENT	7-1
8.0 TROUBLESHOOTING	
8.1 TROUBLE SHOOTING GUIDE	8-1
8.2 ERROR MESSAGE BYTE INFORMATION TABLE	8-2

TABLE of CONTENTS

9.0 STANDARD PREALIGNER DRAWINGS

9.1 PER4MER 3000 PREALIGNER	9-1
9.2 PER4MER 3000 HALF RACK CONTROLLER	9-2
9.3 PER4MER 3000 HALF RACK CONTROLLER WIRING DIAGRAM	9-3

TABLES, FIGURES AND DRAWINGS

PREALIGNER MOUNTING DIMENSIONS	2-3
TABLE 4.1 MAIN STATUS REPLY FROM 'IM' COMMAND	4-18
LOCATION of DIP SWITCH SW2	4-19
NORMAL SW2 DIP SWITCH SETTINGS	4-19
COMMAND SUMMARY	4-21
CPU BOARD LAYOUT	5-1
MOTOR CONTROLLER BOARD LAYOUT	5-2
I/O BOARD LAYOUT	5-3
MOTOR DRIVE BOARD LAYOUT	5-4
RS-232 HOST CONNECTION	5-5
PREALIGNER TROUBLESHOOTING GUIDE	8-1
ERROR MESSAGE BYTE INFORMATION TABLE	8-3
PER4MER 3000 PREALIGNER	9-1
PER4MER 3000 HALF RACK CONTROLLER	9-2
PER4MER 3000 HALF RACK WIRING DIAGRAM	9-3

1. INTRODUCTION

1.1 NON-CONTACT PREALIGNER

The Cybeq Per4Mer 3000-Non-Contact Prealigner is a host-computer-controlled unit that will center semiconductor wafers and position flats and notches accurately. It has the capability of processing wafers of various sizes effectively. It will also center and align square substrates.

The design of the Non-Contact Prealigner is such that it can easily be incorporated into a variety of wafer handling/testing equipment to provide an integrated system.

The (Non-contact Prealigner MODELS) PER4MER 3000 utilize a 1.8 degree/step 4-phase stepping motor with mechanical drive for its theta axis resulting in an angular resolution of .06 degrees (6000 steps/revolution).

PRINCIPAL FEATURES:

- 3" – 12" Wafer capability
- 3" – 7" Substrate capability
- Can locate either Flat or Notch
- RS-232C interface
- Class 10 Clean Room compatible
- Programmable angular positioning
- Wafer size adjustment
- One integrated controller available when utilized with Cybeq Robot
- Optional cable lengths available

2. INSTALLATION

2.1 PACKAGING

A. Stand Alone Prealigner

The stand-alone Prealigner is shipped in two cartons, packed into one larger crate.

One carton contains the Prealigner itself.

The second carton contains:

- Prealigner Control Unit
- Two interconnect cables
- AC Power Cord
- Calibration Wafer
- Operation and Maintenance Manual

B. Integrated Prealigner

The integrated Prealigner is packaged in several containers. The Control Unit for the integrated Prealigner is inside the Robot controller. The Prealigner itself can be found in a separate carton.

Another carton inside the controller carton contains along with Robot items:

- Prealigner Control Unit
- Two interconnect cables
- AC Power Cord
- Calibration Wafer
- Operation and Maintenance Manual

2.2 DISASSEMBLY OF CRATE

CAUTION

Prealigner and Controller are a matched set. Keep set intact when unpacking and during installation.

1. INSPECTION

Inspect the shipping container for signs of damage in transit. If crate is damaged, you may wish to contact the carrier so his/her representative can witness the unpacking. As you unpack, carefully inspect the contents of the shipping crate. Fully document any shipping damage you find, and furnish a signed inspection report to the carrier.

2. UNPACKING PREALIGNER AND CONTROL UNIT

(Refer to standard Prealigner drawing in Section 9.1)

CAUTION

Use extra care when removing the Prealigner from the carton. Lift the Prealigner out of the carton by holding onto the main body.

*After removing the Prealigner from the carton, carefully remove the anti-stick wedge from beneath the optics assembly. **Take care not to scratch or contaminate the optical filter or lens surface. (There should be no particles or fingerprints on the lens surface.)***

3. RETURNED MATERIALS

Store the shipping crate, components and protective wrapping in the event of reshipment to CYBEQ for repair.

Any materials returned to CYBEQ SYSTEMS must be clearly labeled with a Returned Materials Authorization (RMA) number contact:

CYBEQ SYSTEMS
Technical Services
535 Oakmead Parkway
Sunnyvale, CA 94086

Telephone: 408-328-3400
FAX: 408-328-3455

2.3 SYSTEM INSTALLATION

1. MOUNTING PREALIGNER

For mounting the Prealigner use only designated mounting holes (three (3) #8-32 UNC-2B) in the base panel of the Prealigner unit. **The mounting screws should not extend farther than .28-inch into the base panel.**

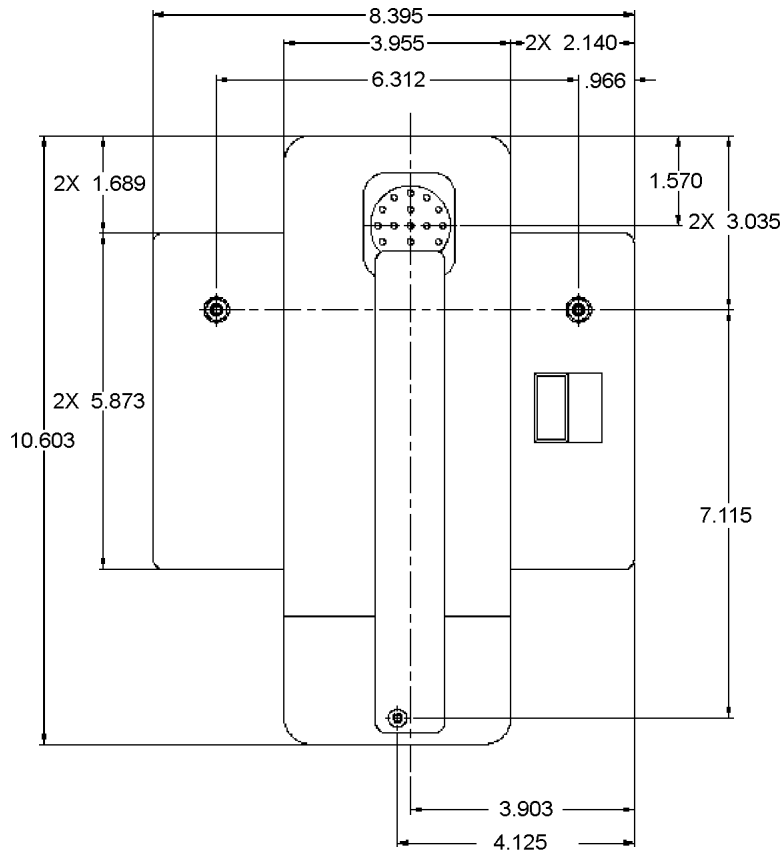

PREALIGNER MOUNTING DIMENSIONS

2. PREALIGNER/CONTROLLER UNIT CONNECTION

Connect the Prealigner and Control Unit by means of the two interface cables supplied by **CYBEQ**:

Video Signal Cable
Prealigner Extension Cable

The appropriate connection designations are clearly labeled on the back panels of the Control Unit and Prealigner.

3. CONTROL UNIT/HOST COMPUTER CONNECTION

Connect customer provided RS-232 interface cable between host computer and Prealigner Controller. There is a 9-pin connector with "RS-232" designation on the back panel of the Control Unit.

4. POWER CONNECTION

The Prealigner has the capability of being used with 90-120 VAC, 220 VAC or 240VAC. The Prealigner's power supply will automatically adjust to the voltage supplied. Change the AC line fuse as required to suit the available line voltage, according to the chart in Section 5.5-2. It may also be necessary to modify the power cord plug to suit the wall receptacle.

After the fuse power cords are properly configured, and after the interface cables have been installed, connect the controller's power cord to the AC power line.

5. VACUUM CONNECTION

To connect the Prealigner to the vacuum supply line, insert a vinyl hose, 1/8" I.D. x 1/4" O.D. (customer provided), into the vacuum fitting located on the vacuum input panel on the Prealigner. (Refer to drawing in Section 9.1)

The supplied vacuum should be according to the Prealigner specifications. The vacuum should be 20 inch Hg (56cm) or higher.

3. SPECIFICATIONS**3.1 UTILITIES**

- | | |
|----------------------|---|
| 1. ELECTRICAL | 90-120 VAC, 50-60 Hz, 4 amps
220-240 VAC, 50-60 Hz, 2 amps
(selected by User) |
| 2. VACUUM | Operating range 20-70cmHg (45cmHg optimum) |

3.2 DIMENSIONS**1. PREALIGNER**

Depth	10.60"	29.6cm
Total Height	9.80"	25.0cm
Box Height	6.34"	16.1cm
Chuck Height	6.59"	16.7cm
Clearance Above Chuck	0.20"	0.5cm
Width	8.40"	21.3cm
Weight		

2. CONTROLLER – HALF RACK

(exclusive of cable connectors and front panel handles)

Depth	20.88"	53.0CM
Height	7.00"	17.8CM
Width	8.37"	21.3CM

3.3 GENERAL SPECIFICATIONS

- | | |
|-----------------------------------|--|
| 1. DRIVE MOTORS | Stepper Type |
| 2. CHUCK | Vacuum chuck with integral precision bearing spindle |
| 3. TRANSPORT COMPATIBILITY | Compatible with robotics wafer handling equipment |
| 4. DETECTION METHOD | CCD sensor |
| 5. MECHANISM | Centering: X – Y Table
Rotation: Rotating vacuum chuck
(No edge contact) |

6. WAFER DIAMETERS	3", 80mm 100mm, 125mm, 150mm, 200mm, 300mm, also half sizes (SEMI standards)
7. CENTERING ACCURACY	MODEL PER4MER 3000 $\pm 0.002"$ ($\pm 0.05\text{mm}$)
8. LINEAR RESOLUTION	0.0002" (0.003mm)
9. ANGULAR ACCURACY	± 15 arc minutes = $\pm 0.125^\circ$
10. ANGULAR RESOLUTION	3.6 arc minutes = 0.06°
11. POSITIONING	Rotation to any desired angle
12. ALLOWABLE INCOMING MISALIGNMENT	$\pm .35"$ ($\pm 6.4\text{mm}$)
13. THROUGHPUT	Flat = 2.5 sec Notch = 3.3 sec

4. OPERATION

4.1 THEORY OF OPERATION

1. The Non-contact Prealigner is, with its controller, a stand-alone unit that handles each command from the host computer sequentially. It has three axes of motion, each driven by a stepper motor: horizontal translation of the vacuum chuck along the X- and Y-axes; rotation of the vacuum chuck about the vertical axis. (The X-axis of the Prealigner is the horizontal axis through the vacuum chuck, the CCD, and the light source; the Y-axis is orthogonal to the X-axis.)
2. A command from the host computer can position the movable sensor along the X-axis to accommodate the desired wafer diameter. DO NOT attempt to move the sensor by hand. The selected diameter is stored in battery-backup static RAM, and is retained until a different diameter is selected.

The host computer can also command SET NOTCH ('SN') or SET FLAT ('SF') to select the desired feature for alignment. The choice is stored in battery-backup static RAM, and is retained until a different choice is made.

3. The two major components of the sensing mechanism are

Illuminator Located directly above the linear CCD

Linear CCD sensor Variations of the wafer shadow, caused by the wafer passing between the illuminator and the sensor, create waveform output signals that provide all information for calculating CENTER OFFSET or FLAT locations

4. After the wafer is placed on the Prealigner vacuum chuck, the host computer is normally instructed to issue a "find" ('FW') or "go" ('GW') command. Vacuum is then applied to hold the wafer firmly. The chuck rotates the wafer. While the wafer the optical sensor scans edge. The wafer's NOTCH or FLAT will be detected, as previously chosen and the CENTER OFFSET will be calculated. The notch or the flat is then oriented to the designated offset angle and the wafer is simultaneously centered. The offset angle may be set using the "set rotation" ('SR') command or as parameters in the "find" ('FW') wafer command.
5. Any initial off center displacement less than ± 0.35 " (± 8.9 mm) is allowed for. If the displacement is greater than $\pm .35$ " then MISALIGNMENT is reported. If the NOTCH is not found, not only does it report NOTCH NOT FOUND, but also no CENTERING action takes place.
6. To avoid jarring the wafer, it is helpful to maintain vacuum on the chuck until just before the robot's end effector is about to remove the centered and aligned wafer. The host computer should issue a VACUUM OFF ('VF') command to release the wafer.

After the robot has removed the centered and aligned wafer, a REFERENCE CHUCK ('RC') command should be issued by the host computer to return the chuck to its reference position, ready for the next wafer.

NOTE

The syntax for Prealigner commands is: "**P0<command>[data]<lf>**"

where **data** is command dependent and **<lf>** represents a line feed.

For the command to "find" a wafer 'FW' the actual command string sent to the Prealigner is "**P0FW<lf>**". See sections 4.3 and 4.8 for further discussions.

4.2 POWER UP

1. The rear panel of the Prealigner Controller has a POWER switch. The power switch toggles when pressed and front indicator light is lighted when power is ON. A RUN LED (red) can be found on the CPU board (CR4). Please refer to section 4.12 for the location of this board.

The RUN light blinks at a steady rate (2/sec) to indicate that the CPU is running.

During POWER UP, the Controller goes through a POWER ON RESET cycle, which sets up internal registers and parameters.

During POWER ON RESET, the chuck is first moved to the HOME sensors of the X- and Y-axes, and then to a predefined REFERENCE POSITION away from the HOME sensor position.

The movable slide carrying the sensor first moves to its HOME sensor and then to the position corresponding to the wafer diameter currently stored in the battery-backup static RAM.

If a RESET problem occurs, a STATUS bit, SYSTEM ERROR (byte 1, bit 0) is set to '1' and STATUS byte #3 is set to a 'A'. See Table 4.1.

To change the wafer diameter setting refer to Section 4.7.

2. During the initialization SELFTEST checks the battery-backup RAM section. If data checksums are incorrect, a status bit, SYSTEM ERROR (byte 1, byte 0) is set to '1' and STATUS byte #3 is set to an 'B'. See Table 4.1.
3. The Prealigner is shipped with the CCD Sensor already calibrated. All calibrated data are stored in the memory-backup RAM.

Procedures for re-calibration the CCD are described in Section 7.1.

Any re-calibration should be performed only after consulting CYBEQ.

4.3 COMMUNICATIONS

1. All communications to the Prealigner are via a RS-232C and are in ASCII format, according to the protocol:

- 9600 baud rate
- no parity
- 8 data bits
- 1 stop bit

The connector for the RS-232 is located on the rear panel of the Controller, is labeled "RS-232", and is a male 9-pin Amphenol 'D';

Refer to Section 5.2.2, for a diagram of the RS-232 port pin out of the 9-pin connector.

2. To facilitate communications between the Prealigner and the host computer, and to increase throughput, only minimal commands 2 bytes long are required. Each byte is represented by an ASCII capital letter from the set A-Z, chosen as a mnemonic to make the desired action easy to recall. For example, 'RS' for RESET PREALIGNER and 'VN' for VACUUM ON.

Any command from the host computer to the Prealigner must commence with the ID bytes 'P0' (P-zero). All commands or transmissions of numerical data must be terminated by a Line Feed (LF, ASCII character 0A hex or 10 dec); for programming in C language, the 'newline' character '\n' would be used. LF also terminates data transmitted from the Prealigner.

For example, in C language the command VACUUM ON would be sent from the host computer to the Prealigner as the ASCII character string "P0VN\n".

3. The RS-232 commands are divided in two groups: REQUEST and ACTION commands.

REQUEST commands will be replied to even when the Prealigner status is BUSY; all ACTION commands will be queued in a 256 byte buffer and executed one after the other.

4. If the Prealigner is not able to recognize a received command, the COMMAND NOT RECOGNIZED status bit (STATUS byte 2, bit 2) will be set.

(Table 4.1). In such a case, the command format should be corrected and sent again.

5. All ACTION commands, after being completed, automatically send the status back to the host. This automatic response has the protocol listed in Table 4.1, the same as for the MAIN STATUS ('IM') command.

Before sending a subsequent ACTION command, it is recommended to check the ready status bit (Table 4.1, STATUS byte 1, bit 3) to ensure that the Prealigner is READY. Also check the error message character in the STATUS byte #3. If it is not '0' then an error has been detected. Note that the Prealigner can both be READY and have an error.

A time-out is recommend for status decoding and interpretation after each ACTION command is sent; send again if the return status (Table 4.1, byte 2, bit 2) indicates that the Prealigner could not recognize the command.

6. REQUEST commands all begin with the letter 'I', an acronym for 'Interrogate'. For the command MAIN STATUS ('IM', Table 4.1), the STATUS BITS (status byte #1) and MODE BITS (status byte #2) are returned in bitwise form, but the ERROR MESSAGE (status byte #3) and WAFER DIAMETER (status byte #4) are returned as characters; refer to Table 4.1

When the Prealigner returns the status, either automatically following an ACTION command or in response to a STATUS REQUEST command ('IM'), the data bits have a special format to facilitate extraction of the status information.

- A. To obtain bits 0 to 3 for both STATUS and MODE subtract '0' from each one. For the significance of each bit refer to Table 4.1.
- B. The ERROR MESSAGE and WAFER DIAMETER status bytes are interpreted as characters.

For example, suppose the prealigner:

- was busy
- vacuum was on
- was not at reference position
- in a flat finding mode
- the wafer was out of the CCD range
- was set for 150 mm (6 inch) wafers

The status returned by the prealigner would be:

"<126\n".

7. When the Prealigner returns an actual number (not status bits), for example in response to commands such as ASK X-AXIS ('AX'), the number is in standard ASCII format.

For example: in response to an 'AR' command, the Prealigner returns the value
12.12345 degrees

The reply sequence to the command "P0AR<lf>" would be:

"12.12345<lf>"

Or, in response to a ASK X-AXIS ('AX') command the Prealigner returns
0.00125 inches.

The reply to the command "P0AX<lf>" would be:

"0.00125<lf>"

8. For the commands FIND WAFER NOTCH/FLAT ('FW'), ROTATE WAFER ('GR'), and SET ROTATION ('SR'), degrees of rotation are expressed as number of motor steps. The rotation range from -180° to $+180^{\circ}$ corresponds to -3000 to +3000 steps, equivalent to 0.06° per step for the model PER4MER 3000.

For commands 'GX','GY', RUN X-AXIS MOTOR ('RX') and RUN Y-AXIS MOTOR ('RY'), the linear translation is expressed as a number of motor steps, equivalent to 0.000125-inch per step. The X-axis travel, referenced to the HOME position, is 0.0000 to 0.7874 inch (0-6300 steps). The Y-axis travel, referenced to the HOME position, is 0.0000 to 0.6300 inch (0-5040 steps).

9. If any error occurs with CCD sensors, motor, or communication devices, the appropriate error message will be generated and/or status bits will be set.

4.4 STANDARD DIP SWITCH SETTINGS

1. An 8-position Dipswitch (SW2) is located on the CPU board in the prealigner controller card cage. The switch is located near the four LED's (CR4-CR7) in the middle of the board.

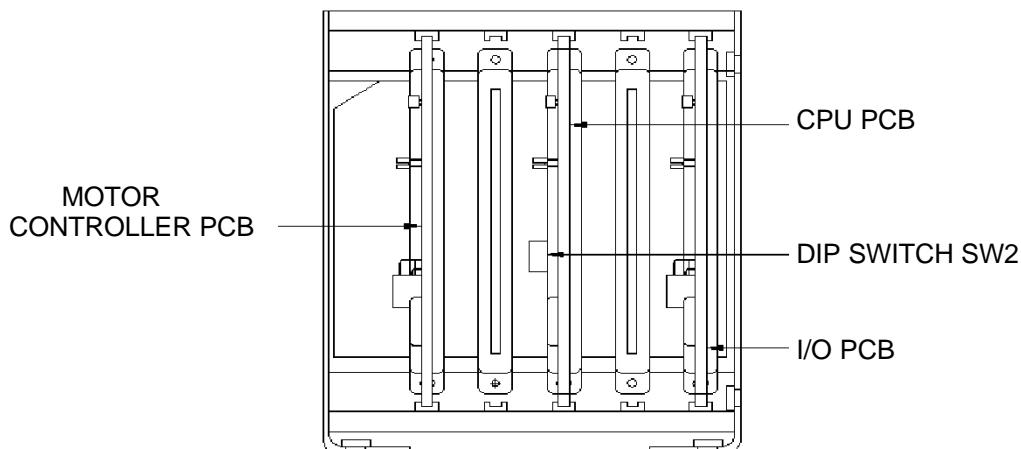

LOCATION OF DIPSWITCH SW2

The purpose of the Switch Setting is to allow simple testing without using the host computer, and to set various operating features. Although only a limited number of tasks are allowed, many switch functions are equivalent to command functions.

The following notation is used to describe the switch settings:

- 0 = switch is OFF, rocker is nearest the OPEN or OFF label
- 1 = switch is ON, rocker is away from the OPEN or OFF label
- X = switch setting is immaterial

- 2. For normal operation with commands issued by the host computer through RS-232 to the Prealigner, SW2 should be set to NORMAL MODE as follows:

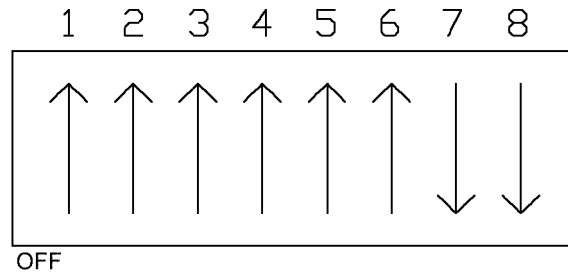

NORMAL SW2 DIP SWITCH SETTINGS

- 3. The diagnostic ACTION commands listed in Section 4.8 cannot be called by the host computer unless SW2 is set to DIAGNOSTIC MODE, as follows:

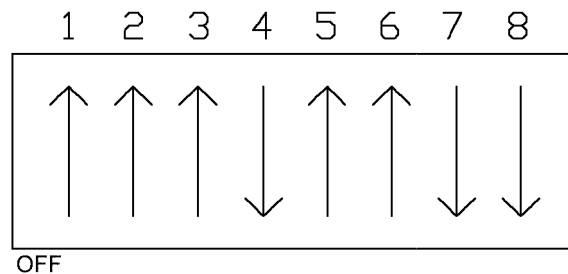

- 4. A complete list of function settings of SW2 is given in Section 4.1.

4.5 TEST OPERATION

- 1. Dip switch SW2 can be set to allow a continuous cycle of FLAT finding, with no input required from a host computer.

The cycle sequence consists of moving the chuck to the REFERENCE POSITION (equivalent to the command 'RC'), and then finding the FLAT and aligning it at 45 degrees (equivalent to the command 'FW750').

- 2. It is assumed that wafer size diameter has been stored in battery-backup RAM by previously issuing the 'S6' command. (Refer to Section 4.7). It is assumed that the instruction to find the notch or flat has also been stored, by previously issuing the SET FLAT ('SF') command.

It is assumed that the Prealigner is properly connected to vacuum and is properly connected to the Controller.

3. To set the test cycle, turn the main Controller power OFF and set Dip switch SW2 as follows:

Switch no.: 1 2 3 4 5 6 7 8
Setting: 0 0 1 1 1 1 1 0
(0 = switch OFF; 1 = switch ON)

Place a 6" wafer on the chuck, with no more that 0.35-inch misalignment. Vacuum will be applied to the chuck automatically when the cycle starts.

To begin the test cycle, turn the main Controller power ON. To end the cycle, turn the main Controller power OFF.

4.6 NOTCH/FLAT FINDING

1. For convenience, this section describes the command sequence to be used for normal NOTCH/FLAT finding.

It is assumed that the Prealigner is properly connected to vacuum and is properly connected to the Controller. It is assumed that a host computer is properly connected to the Controller. It is assumed that the Controller is set to NORMAL MODE (see Section 4.4).

If the supply vacuum is not ON, or if the pressure is otherwise not sufficient, NOTCH/FLAT finding will not occur. An error message 'Vacuum Link Failure' will be reported in the Main Status, according to the protocol in Table 4.1.

It is assumed that the Prealigner has been set to the chosen wafer diameter by previously issuing an 'S3'- 'S8' command. It is assumed that the instruction to find the notch or to find the flat has been previously issued using the SET NOTCH ('SN') command or the SET FLAT ('SF') command.

2. All commands from the host computer to the Controller must begin with the ID 'P0'. (P "ZERO" not the letter "O")
 - " Before the wafer is loaded onto the chuck, send the chuck to its REFERENCE POSITION by issuing the command 'RC'.
 - " After a wafer of the chosen diameter has been placed on the chuck (allowable misalignment is ± 0.35 inch = 6.4 mm), issue either the FIND command 'FW' together with the desired reposition angle of units of steps.

Steps (1 step = 0.06 degree for model PER4MER 3000) or the Go Wafer command 'GW'. As an example, 'FW3000' means find the notch/flat and reposition angle of 0-degrees.

'GW' is a faster command to find the NOTCH/FLAT, but the 'SRxx' command, which saved the rotational angle offset in battery-backup RAM, must be performed first.

- .. When the NOTCH/FLAT finding and repositioning are completed, status will be sent from the Controller to the host computer according to Table 4.1. The status is analyzed to ensure that operation was performed correctly.
- .. After analysis of status to ensure correct operation, and just before the wafer is retrieved from the chuck, issue a VACUUM OFF ('VF') command to release the wafer.

4.7 WAFER DIAMETER SETTING

1. The Prealigner is equipped with a computer-controlled wafer size adjustment, DO NOT attempt to move the slide manually. The slide moves only in response to a command 'WD<value>' or 'SX<value>' from the host computer. See the respective command descriptions in Section 4.8 for the complete command formats.

Once entered, the chosen wafer size remains in effect (the value is stored in nonvolatile memory), even if the Controller is turned off, until a new diameter is entered.

4.8 ACTION COMMANDS

1. Commands transmitted from the host computer to the Prealigner via RS-232 should commence with the ID bytes 'P0' (P-zero). The command should be terminated by a line feed lf (ASCII character 0A hex or 10 dec); for programming in C language, the 'new line' character '\n' would be used. When entering commands directly from a keyboard, it is supplied by pressing the ENTER key.

The format for a command line from the host computer to the Prealigner can be represented symbolically as:

<ID bytes><command bytes><num data><lf>

Numerical data (which should be in ASCII) may or may not need to be included, depending upon the particular command.

The Prealigner transmits status bits/numerical data to the host computer automatically following the completion of an ACTION command, or in response to an interrogation from the host computer. The numerical data are ASCII, and the message is terminated by lf.

When the Prealigner transmits floating-point numerical data, the reply typically contains spaces (ASCII 20 hex) and a decimal point (ASCII 2e hex). For negative numbers, a minus sign (ASCII 2d hex) will replace one of the spaces. The explicit format employed is described in Section 4.8.2 for particular commands.

2. NORMAL ACTION COMMANDS

'AL' ASK LOAD ANGLE

This command causes the Prealigner to return the substrate load angle stored in RAM (of the 'LA' command). The angle is expressed in units of steps (1 step = 0.06 degree over the range -3000 to +3000 steps). The format consists of a combination of five spaces and numbers, with no decimal point. For negative numbers, the space immediately preceding the first significant figure is replaced by a minus sign. For example if the load angle had been set to 100 (steps) sending the command "POAL<lf>" to the prealigner would generate the response " 100<lf>". Note that there are two leading spaces in the response because of the fixed five-digit format.

'AR' ASK R-AXIS

This command causes the Prealigner to reply with the original location of the Flat/Notch offset angle (in degrees) resulting from the previous FIND ('FW' or 'GW') command. The format is a floating-point number consisting of a combination of up to three figures left of the decimal point and five figures to the right.

Examples:

12.12345 deg	would be "12.12345<lf>"
121.00000 deg	would be "121.00000<lf>"
.05000 deg	would be "0.05000<lf>"

'AX' ASK X-AXIS

'AY' ASK Y-AXIS

These commands cause the Prealigner to reply with the X- or Y-translational offsets in inches or steps resulting from the previous FIND ('FW') or GO WAFER ('GW') commands. The format is a floating-point number consisting of a combination of up to three figures left of the decimal point and five figures to the right. For negative numbers, the space immediately preceding the first significant figure is replaced by a minus sign.

Examples:

1000 steps	would be "1000<lf>"
100 steps	would be "100<lf>"
-100 steps	would be "-100<lf>"

'FW' FIND WAFER NOTCH/FLAT

This command to the Prealigner is the one usually employed to perform a wafer alignment. The 'FW' command automatically causes the vacuum to be applied to the chuck. The format consists of the ID, the command bytes FW, numerical data, and <lf>. The optional numerical data are 1 to 4 numbers (with minus sign if needed) representing the desired offset angle in units of steps (1 step = 0.06 degree over the range -3000 to +3000 steps for model PER4MER 3000). If the numerical data are omitted, the default-offset angle is 0 degrees.

Examples:

"P0FW3000<lf>" Align with 180 degree offset

'GW' GO WAFER (to find NOTCH/FLAT)

This command to the Prealigner is essentially the same as the 'FW' command, except that the desired offset angle is read from battery-backup RAM (cf 'SR' command). No numerical data are included in the format for this command.

Examples:

"P0GW<lf>" Align with 180 degree offset

'GX' MOVE X-AXIS RELATIVE

This command to the Prealigner moves the chuck from its present X-position to a new position by the relative motor step value. The format consists of the ID, the command bytes, numerical data and <lf>. The numerical data are 1 to 4 digits (with minus sign if appropriate) representing the desired X-axis offset in units of motor steps, over the range of -3000 to +3000 steps for model PER4MER 3000.

Examples:

"P0GX-55<lf>" Move chuck in X-axis from current position.

'GY' MOVE Y-AXIS RELATIVE

This command to the Prealigner moves the chuck from its present Y-position to a new position by the relative motor step value. The format consists of the ID, the command bytes, numerical data and <lf>. The numerical data are 1 to 4 digits (with minus sign if appropriate) representing the desired Y-axis offset in units of motor steps, over the range of -3000 to +3000 steps for the model PER4MER 3000.

Example:

"P0GY130<lf>" Move chuck in Y-axis from current position.

'GR' ROTATE WAFER

This command to the Prealigner rotates the chuck through an assigned angle (from current position). The format consists of the ID, the command bytes, numerical data and <lf>. The numerical data are 1 to 4 numbers (with minus if needed) representing the desired offset angle in units of steps (1 step = 0.06 degree over the range -3000 to +3000 steps for model PER4MER 3000).

Example:

"P0RW1500<lf>" Rotate the chuck 90° from the current position

NOTE

DO NOT use 'GR' to rotate the wafer following 'FW', because if the wafer is not perfectly centered on the chuck, rotation of the chuck by "PW" will change the X- and Y- centering offset.

'LA' SET LOAD ANGLE

This command to the Prealigner is used to set an angle from which the reference edge of the square substrate will be selected. The side that intersects this load angle will be the reference side. The offset is stored in battery-backup RAM, for use with the 'GW' command. The format consists of ID, the command bytes LA, numerical data, and <lf>. The numerical data are 1 to 5 numerical digits (with minus sign if needed) representing the desired offset angle in units of steps. 1 step = 0.06 degree over the range -3000 to +3000 for model PER4MER 3000.

Example: (step values given for model PER4MER 3000)

"P0LA2700<lf>" sets the load angle to 2700 (steps). If the load angle is set to 2700 steps (162 degrees) and the rotation offset is set to 3000 steps (180 degrees), the substrate side intersecting the 162 degree angle (side "A" in **Figure 4.1**) will be in the 3000 step (180 degree) position after centering and rotation, **Figure 4.2**.

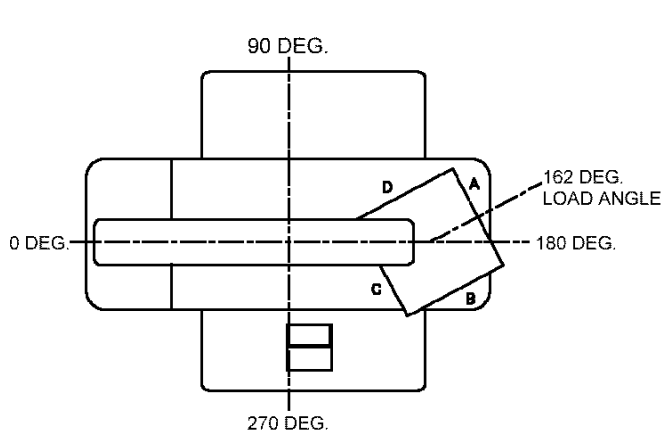

FIGURE 4.1

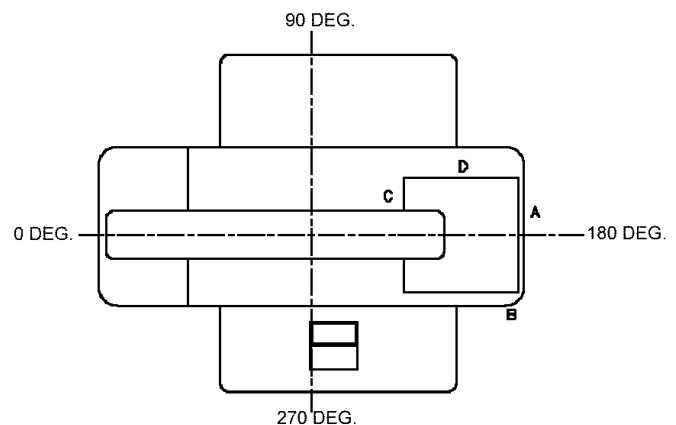

FIGURE 4.2

'RC' REFERENCE CHUCK

This command to the Prealigner moves the chuck to REFERENCE POSITION.

Example:

```
"P0RC<lf>"
```

'RS' RESET PREALIGNER

This command to the Prealigner performs a reset identical to the POWER ON reset: the chuck is moved to the HOME sensors and then to the REFERENCE POSITION.

Example:

```
"P0RS<lf>"
```

'SX' SET WAFER DIAMETER

This command to the Prealigner commands the movable slide to go to the proper position for aligning wafers of the diameter specified by the single digit code number X:

Example:

```
"P0SX<lf>"
```

<u>X</u>	<u>WAFER DIAMETER</u>
3	3 inch
4	100mm (4 inch)
5	125mm (5 inch)
6	150mm (6 inch)
8	200mm (8 inch)
12	300MM (12 inch)

The set wafer diameter then remains in effect (value is stored in nonvolatile memory), even if the Controller is turned off, until a different diameter is commended.

Example:

```
"P0S6<lf>" Set wafer diameter to 150mm
```

'SF' SET FLAT (finding mode)

This command to the Prealigner instructs the Prealigner to search for the flat during alignment. The flat-finding mode then remains in effect, even if the Controller is turned off, until a different mode is commanded.

Example:

```
"P0SF<lf>" Set mode to flat finding
```

'SN' SET NOTCH (finding mode)

This command to the Prealigner instructs the Prealigner to search for the notch during alignment. The notch-finding mode then remains in effect, even if the Controller is turned off, until a different mode is commanded.

Example:

"P0SN<lf>" Set mode to notch finding

'SR' SET ROTATION

This command to the Prealigner is used to enter a pre-assigned offset angle in battery-backup RAM, for use with the 'GW' command. The format consists of the ID, the command bytes SR, numerical data, and <lf>. The numerical data are 1 to 4 numbers (with minus sign if needed) representing the desired offset angle in units of steps (1 step = 0.06 degree over the range -3000 to +3000 steps).

Example:

"P0SR-750<lf>" Set the offset angle to -45°

'SS' SET SQUARE PLATE SIZE

Set square plate size to x[x] where x[x] can be

3	for 3 inch square plate	35	for 3.5 inch square plate
4	for 4 inch square plate	45	for 4.5 inch square plate
5	for 5 inch square plate	55	for 5.5 inch square plate
6	for 6 inch square plate	65	for 6.5 inch square plate
7	for 7 inch square plate		

Example:

"P0SS3<lf>" To set the substrate size to 3 inch:

"P0SS35<lf>" To set substrate size to 3.5 inch:

'TS' TURN SLOWLY

Set the rotation speed of the chuck to 3000 steps/sec (0.5 rps). This is the default rotation speed in large substrate mode and is recommended for larger substrates. This command is used to change speeds again after 'TF' (turn fast command).

Example:

"P0TS<lf>"

'TF' TURN FAST

Set the rotation speed of the chuck to 6000 steps/sec (0.5 rps). This speed can be used for small substrates. If the chuck motor stalls while running at this speed then a slower speed must be set using the 'TS' command (turn slowly).

Example:

"P0TF<lf>"

'TV' TELL VERSION

This command causes the Prealigner to reply with the firmware version.

Example:

```
Tell firmware version      "P0TV<lf>"
Prealigner reply          "FLWR5.41<lf>"
```

'VF' VACUUM OFF

This command to the Prealigner turns off vacuum to the chuck, allowing the aligned wafer to be removed. This command needs to be entered explicitly following alignment, just before the wafer is to be removed from the chuck.

Example:

```
"P0VF<lf>"      Turn off vacuum to the chuck.
```

'VN' VACUUM ON

This command to the Prealigner turns on vacuum to the chuck. It is not used during normal wafer processing, because vacuum is automatically applied when an 'FW' or 'GW' command is issued.

Example:

```
"P0VN<lf>"      Turn on vacuum to the chuck
```

'WD' SET WAFER DIAMETER

This command to the Prealigner commands the movable slide to go to the proper position for aligning wafers of the diameter specified. The format consists of the ID, the command bytes, numerical data <value> and <lf>.

<VALUE>	WAFER DIAMETER	<VALUE>	WAFER DIAMETER
3	3 inch	35	3.5 inch
4	4 inch (100mm)	45	4.5 inch (112mm)
5	5 inch (125mm)	55	5.5 inch (137mm)
6	6 inch (150mm)	65	6.5 inch (162mm)
8	8 inch (200mm)	85	8.5 inch (212mm)

The set wafer diameter then remains in effect (value is stored in nonvolatile memory), even if the Controller is turned off, until a different diameter is commanded.

Example:

```
"P0WD6<lf>"      Set wafer diameter to 150mm
```

3. DIAGNOSTIC MODE ACTION COMMANDS

The commands described in this section are recognized only if Dip switch SW2 in the Controller box is set to DIAGNOSTICS MODE. (Refer to Section 4.4.3)

Cybeq Field Service or Engineering reserves certain DIAGNOSTICS MODE commands not described in this section for troubleshooting and adjustment.

'CB' CALIBRATE (the CCD)

Calibration is not a normal procedure

Any re-calibration should be performed only after consulting CYBEQ.

To perform a calibration, a special centering wafer (Cybeq P/N 0123-90xx) is required. Procedures for re-calibrating the CCD are described in Section 7.1. Note that after the 'CB' command is issued to the Prealigner, calibration does not begin until vacuum is applied to the chuck using the 'VN' command.

'RA' RUN AUXILLARY (HEAD) MOTOR

'RX' RUN X-AXIS MOTOR

'RY' RUN Y-AXIS MOTOR

These commands to the Prealigner cause an X-, Y-axis or A-axis translation to an absolute position as measured from the HOME sensor position. The position is specified as a number of steps 0-9999 (1 step = 0.000125 inch = 0.003175mm).

X-axis maximum distance of travel is 0-6.300 steps (0.7875 inch = 20.00mm).

Y-axis, the maximum distance of travel is 0-5040 steps (0.6300 inch = 16.00mm).

A-axis the maximum distance of travel is 2.5 inches.

Example: Move the X-axis to 0.125 inch from the HOME sensor

```
"P0RX1000<lf>"
```

'TL' TELL INPUTS

This command causes the Prealigner to reply with the status of the Prealigner Digital Vacuum Sensor, X-axis limits and Auxiliary limits. The response will be 4 ASCII digits 'X1X2X3X4' as follows:

X1-Vacuum Status bit

0 = Vacuum OFF.

2 = Vacuum ON.

X2-X-Axis Limit Status bit

- 0 = Not at limits.
- 2 = At Full Limit.
- 3 = Home Position.

X3-Y-Axis Limit Status bit

- 0 = Not at limits.
- 2 = At Full Limit.
- 3 = Home Position.

X4-Auxillary Limit Status bit

- 0 = Not at limits.
- 2 = At Full Limit.
- 3 = Home Position.

Example:

Vacuum ON, X-axis not at limit, Y-axis at full limit, Auxiliary at Home position.

Response = "2024<lf>"

4.9 STATUS REQUESTS and RESPONSES**1. STATUS REQUEST COMMANDS**

The STATUS REQUEST commands cause the Prealigner to send the requested status, which consists of four bytes to the host computer. Each byte in the status may be interpreted in either bit wise form or as a character. Table 4.1 later in this section present interpretation of the status bytes for the 'IM' status interrogation command.

If a status byte is interpreted bit wise subtract '0' (ASCII 0) from the status byte to obtain the four status bits.

'IM' INTERROGATE MAIN STATUS

This command to the Prealigner causes the Prealigner to send the four main status bytes to the host computer in the form of "<Status Bits byte><Mode Bits byte><Error Message byte><Wafer Diameter byte><lf>". Status Bits byte and Mode Bits byte are interpreted bit wise, Error Message byte and Wafer Diameter byte are interpreted as characters. Refer to Table 4.1 at the end of this section. Note that the status response to this command is the same status sent on completion of all ACTION commands.

For example, suppose for the prealigner:

- the vacuum was on
- was not at reference position
- in a flat finding mode
- the wafer was out of the CCD range
- was set for 150mm (6 inch) wafers

The status returned by the prealigner would be:
"2126\n"

OFFSET VALUE LETTER	CORRESPONDING SYMBOL
A	:
B	;
C	<
D	=
E	>
F	?

TABLE 4.1 MAIN STATUS REPLAY FROM 'IM'

BYTE	BIT	VALUE	STATUS	
Byte 1 (STATUS BITS)	0	0	System OK	
		1	System Error	
	1	0	Vacuum Switch OFF	
		1	Vacuum Switch ON	
	2	0	Not at Reference Position	
		1	At Reference Position	
	3	0	Ready	
		1	Busy	
Byte 2 (MODE BITS)	0	0	Notch Search Mode	
		1	Flat Searching Mode	
	1	0	Normal Mode	
		1	Diagnostics Mode	
	2	0	Command Recognized	
		1	Command Not Recognized	
	3	0	Wafer Mode	
		1	Square Plate or Constant Position Mode	
	Byte 3 (ERROR STATUS)		VALUE	MESSAGE
			0	No error
		1	CCD measurement error	
		2	CCD out of range	
		3	Displacement >0.25 inch	
		4	Limit Switch Error	
		5	Motor board time-out	
		6	Motor board Comm. Error	
		7	Notch/Flat not found	
		8	Vacuum sensor error	
		9	Vacuum supply failure	
		A	Reset not performed	
		B	NV-SRAM data mismatch	
	C	Invalid parameter		
	D	Bad calibration data		
Byte 4 (WAFER DIAMETER)		VALUE	DIAMETER	
		2	300mm (12 inch)	
		3	3 inch	
		4	100mm (4, 4.5 inch)	
		5	125mm (5 inch)	
		6	150mm (6 inch)	
		8	200mm (8 inch)	

4.10 DIP SWITCH SETTINGS and CONFIGURATION

Dipswitch SW2 is located on the CPU board in the PreAligner controller cardcage. The switch is near the four LEDs CR4-CR7 at the center of the board.

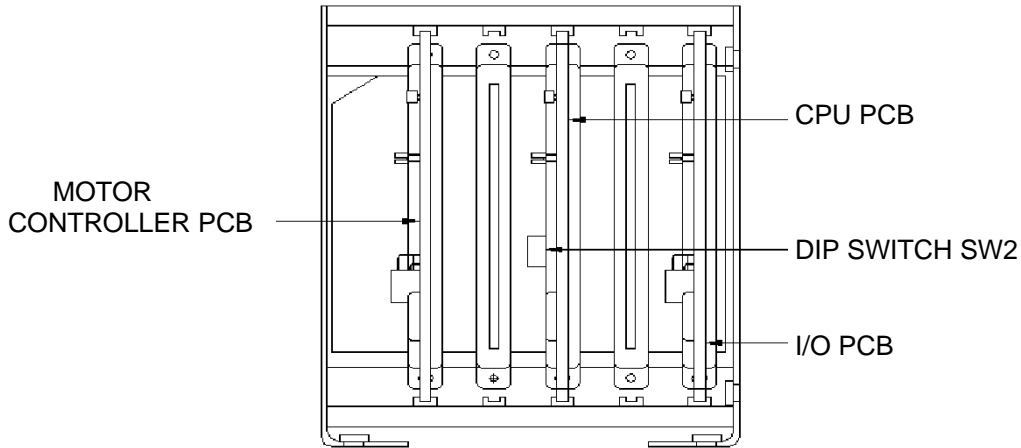

LOCATION OF DIPSWITCH SW2

SW2 has eight (8) ON/OFF rocker switches 1-8. A switch is OFF if the rocker is nearest the label "OFF".

The purpose of the Switch Setting is to allow simple testing without using the host computer, and to set various operating features. Although only a limited number of tasks are allowed, many switch functions are equivalent to command functions.

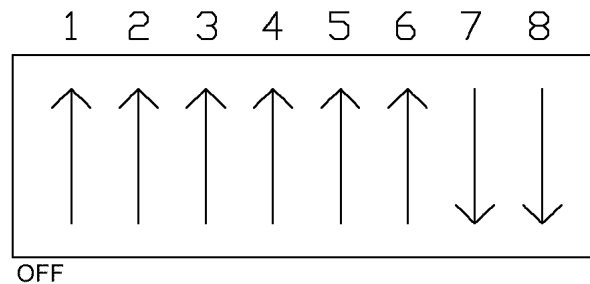

NORMAL SW2 DIP SWITCH SETTINGS

The function of the switches can be summarized as follows:

Switches 1-2:

In various ON/OFF configurations, these switches enable certain modes or actions. Contact Cybeq Systems for more information.

Switch 3:

Not used.

Switch 4:

Diagnostic Mode when in OFF position.

Switch 5:

OFF selects baud rate = 1200

ON selects baud rate = 9600.

Switch 6:

Alternate command set selected when OFF.

Switch 7:

Set to OFF.

Switch 8:

Set to OFF.

NOTE The settings of SW2 should not be changed unless the main Controller power is OFF. Any mode or action chosen will commence when the power is again turned ON or RESET ('RS') command is issued.

4.11 CONTROLLER BOARD LED

CR4 (bit 0) - flashing red LED indicates that the system's hardware/software is running. The blink rate is approximately 2/sec.

CR5 (bit 1) - unused

CR6 (bit 2) - unused

CR7 (bit 3) - unused

4.12 COMMAND SUMMARY

The function of the switches can be summarized as follows:

- AL** Ask Load Angle. Send the current substrate load angle.
- AR** Ask Rotation. Send the offset angle from previous 'FW' or 'GW' command.
- AX** Ask X-Axis. Send the X Axis translation offset from previous 'FW' or 'GW' command
- AY** Ask Y-Axis. Send the X Axis translation offset from previous 'FW' or 'GW' command
- AS** Ask Steps. Send the Rotation Offset Value stored in nonvolatile RAM.
- CB** Calibrate Prealigner
- DP** Define current slider position as reference position
- DR** Define current rotation position as Home
- DX** Define current X position as Home
- DY** Define current Y position as Home
- FW<offset>** Find Wafer Flat/Notch, then align it to <offset>. If no value is given for offset then the offset is assumed to be zero.
- FY** Find the Y axis position of the chuck
- GSN<steps>** Set minimum motor speed
- GW** Go Wafer (find Flat/Notch). Align wafer to offset stored in nonvolatile memory.
- GX <steps>** Move X-axis relative specified value.
- GY<steps>** Move Y-axis relative specified value.
- GR<steps>** Rotate chuck relative specified value.
- IS** Interrogate and return communication status
- IM** Interrogate Main Status. Send the Main Status.
- TV** Interrogate Version Number.
- LA<steps>** Set the substrate load angle to <steps> and store it in memory.
- PF** Enable Constant Position Feature Mode
- RC** Reference Chuck.

- RS** Reset Prealigner.
- RA<steps>** Run Head to absolute position <steps>. Available only in Diagnostic Mode.
- RW<steps>** Rotate the chuck <steps> in the R-Axis
- RX<steps>** Run X to absolute position <steps>. Available only in Diagnostic Mode.
- RY<steps>** Run Y to absolute position <steps>. Available only in Diagnostic Mode.
- SC** Read pixels from the CCD anytime
- SF** Set mode to flat finding.
- SN** Set mode to notch finding.
- SR<steps>** Set the rotation-offset angle to <steps> and store in nonvolatile RAM.
- SS<value>** Set Square plate size in 0.5" increments.
- Sx** Set wafer diameter to x. (x = size: 2,3,4,5,6,8)
- SX<steps>** Set new X reference (Default 4000)
- SY<steps>** Set new Y reference (Default 2900)
- TP** Output current R, X, Y and A positions
- TS** Set chuck speed to slow, 3000 steps/sec (Default 300mm)
- TF** Set chuck speed to fast, 6000 steps/sec (Default 3inch-200mm)
- TI** Interrogate Inputs.
- VF** Vacuum off.
- VN** Vacuum on.
- WD<value>** Set Wafer Diameter to <value>. Used to set wafer diameter in 0.5" increments.

5 ELECTRONICS GENERAL DESCRIPTION

This section describes the Prealigner Control Systems: its architecture, electrical interfaces and internal controls.

5.1 SYSTEM ARCHITECTURE

1. CONTROL SYSTEM

A. CPU Board

The CPU Board is the central processing unit for the Prealigner computer system. This board features an 80C186 CMOS High Integration 16-bit microprocessor running at 10 MHz.

The memory section consists of 64K byte EPROM, 64K-byte static RAM and 64K-byte non-volatile SRAM. The non-volatile SRAM is used to store calibration data.

The basic control program is stored in an EPROM.

An RS-232 serial link provides full duplex communications with the customer's host computer (RS-232 host).

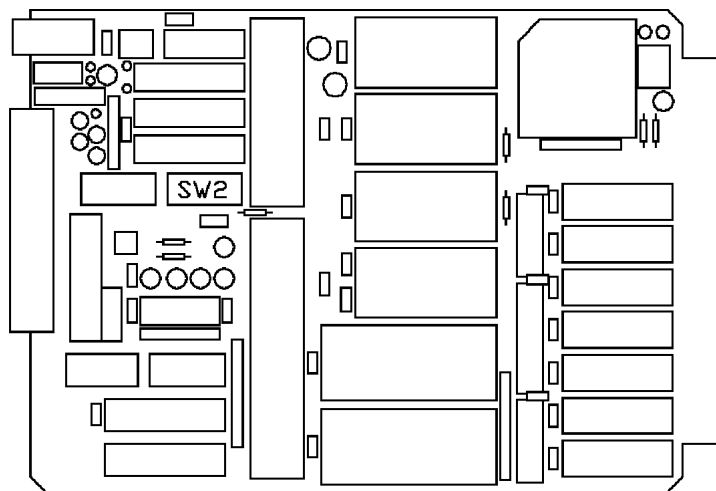

Figure 5.1
CPU BOARD LAYOUT

Figure 5.1 is the layout of the CPU board. The CPU boards are almost identical for the PER4MER 3000 model.

B. High Performance Stepper Motor Controller.

Figure 5.2 shows the general component layout of the Model 4336C Stepper Motor Controller board. The 4336C is a STD (Standard Bus) based computer system which is capable of controlling up to four independent stepper motor drivers. Each control axis provides two limit inputs, one end limit and one home limit. The pulse/direction output allows a step rate of up to 16,000 pulses-per-second. Inputs are debounced and outputs are open-collector transistors.

Each card provides seven open collector general purpose latch outputs which may be read by the control host computer at any time.

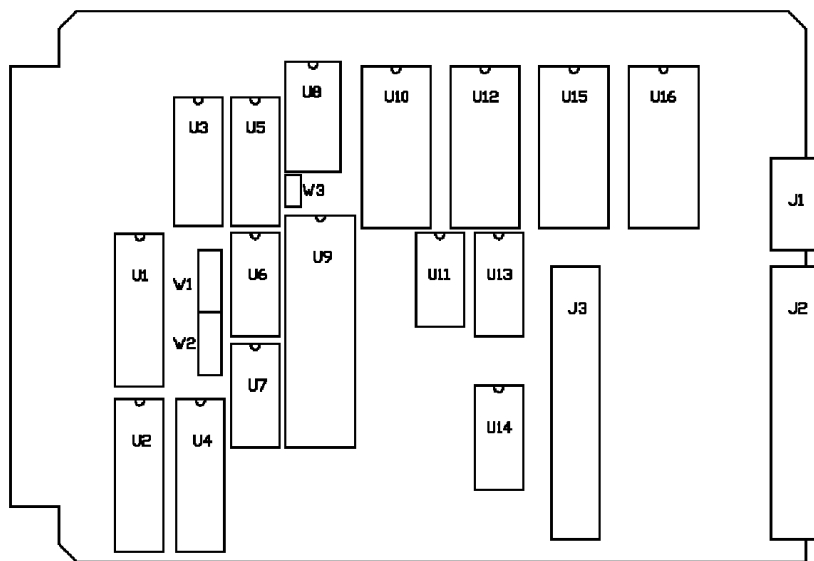

Figure 5.2

MOTOR CONTROLLER BOARD LAYOUT

The card is controlled through user-accessible internal registers. Data registers enable specification of the following parameters:

- " Number of motor steps
- " Low speed rate
- " High speed rate
- " Accel/Decel rate
- " Ramp-down point

Intelligent control devices (one per axis) enable programmable velocity profiling including direction. Four programming modes and six operating modes may be selected. Figure 5.2 is a functional block diagram of the Model 4336C controller.

C. High Performance Sensor I/O Board

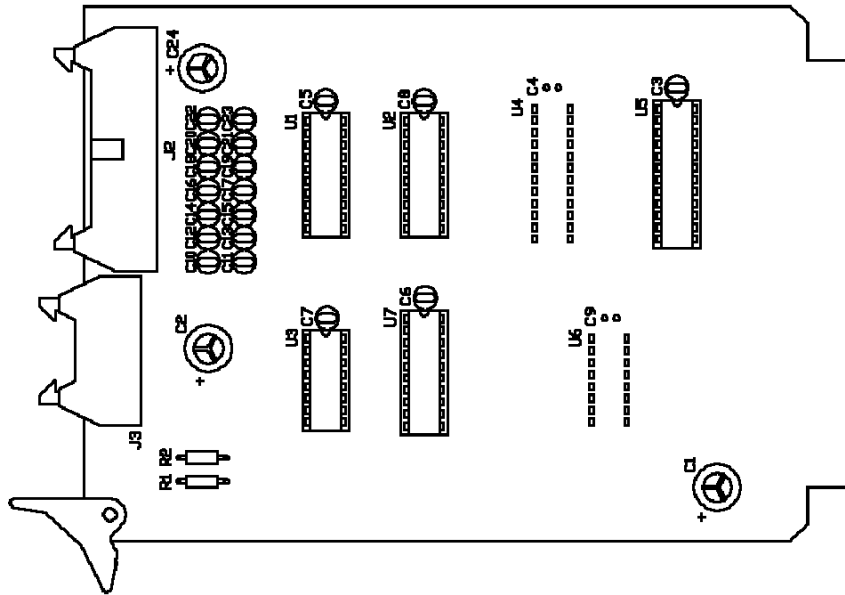

Figure 5.3

SENSOR I/O BOARD

D. Motor Drive Board

The Motor Drive Board contains the dual bridge driver for the stepper motor and solenoid driver.

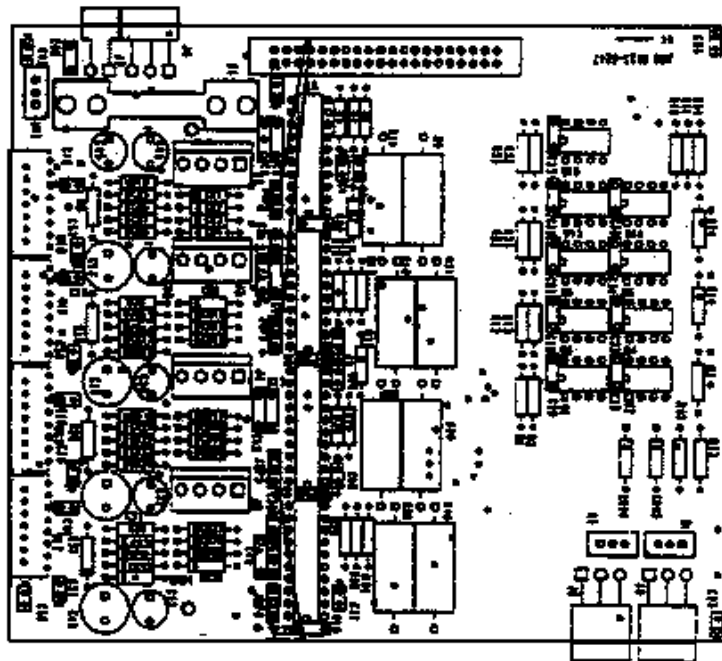

Figure 5.4

MOTOR DRIVE BOARD LAYOUT

5.2 ELECTRICAL INTERFACE CONNECTION**1. AC POWER CORD**

Plug the AC power cord into the rear of Prealigner Control Unit and into power receptacle. Use proper receptacle for 110 or 220 volts AC.

AC Power:

Fuse: 110/220 VAC

50 Hz/60Hz

4 Amp/2 Amp

2. RS-232C HOST CONNECTION

An RS-232C serial port interface is used to connect the Prealigner Control Unit to host computer.

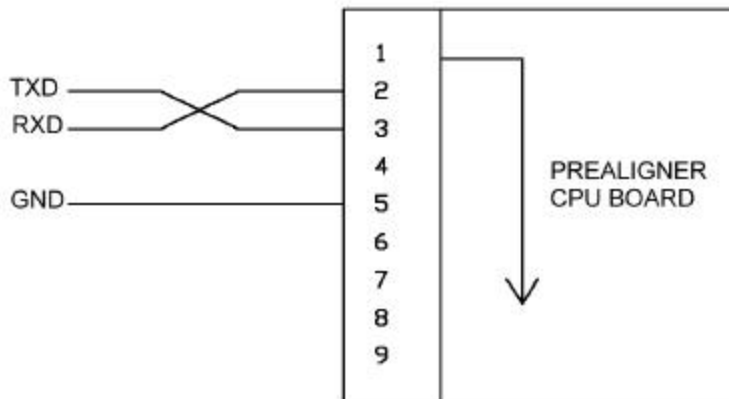
A. Connections to the Prealigner port**RS-232 INTERFACE CONNECTION****B. Communication Parameters**

Baud Rate: 9600 (default), or 1200 if set by DIP Switch (Section 4.8)

Parity: No

Stop Bits: 1

Data Bits: 8

5.3 PREALIGNER UNIT ELECTRONICS

The Prealigner unit contains several electrical and electronics devices that are connected to the Control Unit through the cabling.

Two high precision mechanical switches and two optical switches act as limit switches for the X-Y table. Another optical switch is used for setting the movable slide to different wafer diameters.

The movable slide of the Prealigner carries the CCD sensor. The power and signal for the CCD sensor are transmitted to the Prealigner via the I/O PC Board located in the controller.

The Prealigner unit also contains an electrically operated solenoid valve to switch chuck vacuum on and off. A vacuum sensor in the Prealigner unit indicates the presence or absence of vacuum on the chuck.

5.4 DIP SWITCHES

An 8-position switch is located on the CPU PC Board. Switches settings are:

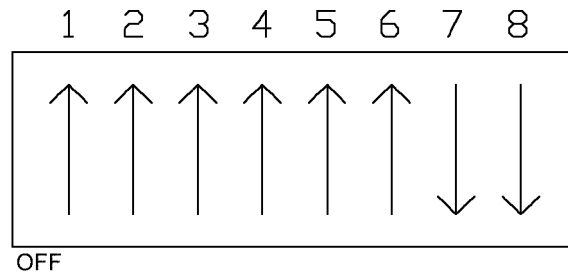

SW2 NORMAL SWITCH SETTINGS

5.5 FUSES / FAN

1. Three fuses protect the three PC boards located in the Prealigner Control Unit; two on the PC Boards and one AC fuse:

LOCATION	PC BOARD FUSE RATING		TYPE
	CURRENT	VOLTAGE	
Motor Control Board	3 AMP	125V	Fast-blo submini
Motor Driver Board	4 AMP	250V	Fast blo

2. The AC fuse is located in the Line Filter of the Prealigner Control Unit.

OPERATING VOLTAGE	LINE FUSE RATING		
	CURRENT	VOLTAGE	TYPE
110	4 AMP	250V	Fast-blo
Motor Driver	2 AMP	250V	Fast blo

3. FAN

The fan, which is connected to the +24 VDC power supply, provides cooling to the internal circuitry of the Prealigner Control Unit.

6 MECHANICAL MAINTENANCE

6.1 PRECAUTIONS

1. The Prealigner should always be disconnected from its power source whenever maintenance work is being performed.
2. Utmost care should be taken when handling the Prealigner. The Prealigner unit should never be lifted or handled using the Sensor Cover.

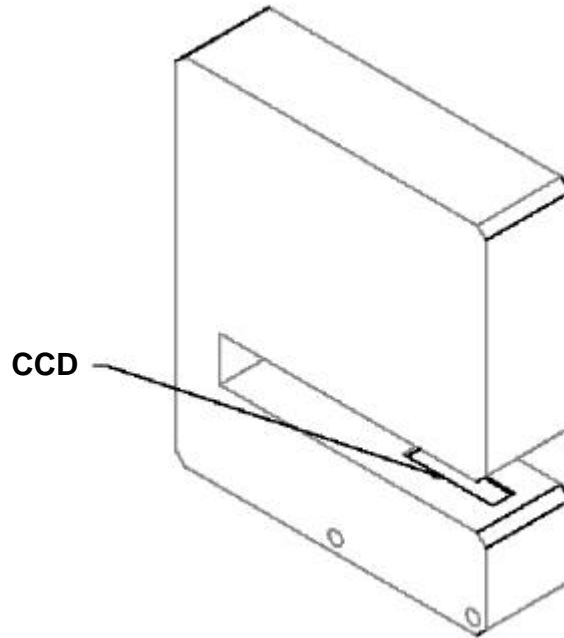

- A. Surfaces of the optical components should not be touched. There should be no contamination, i.e., fingerprints, dust, or scratches, on the Optical Filters or Lens.
- B. No object of any kind should ever be placed into the open area of the top plate surrounding the vacuum chuck and sensor slot.

6.2 PERIODIC MAINTENANCE

NOTE The mechanical moving parts of the Prealigner do not require lubrication.

1. BI-MONTHLY

- Clean the upper surface of the vacuum chuck cover.
- Use a soft lint-free cloth and isopropyl alcohol.
- Check pressure on the vacuum supply line for a minimum of 20 inch Hg.
- Inspect outside surfaces of the optical filter and the lens (CCD Sensor) for cleanliness.

DO NOT CLEAN the optical filter and lens unless a slightly "dirty surface" has as appreciable effect on the performance of the component.

Any cleaning operation has some anticipated risk of degrading the surface. The optical filter and lens have only a small area sensitive to degradation; this area is the narrow strip of the diameter along the X-Axis.

Excess dust can be removed by blowing with clean, dry air (e.g., with compressed gas of Oriel's Microfilter duster #4905 - when using, keep the can perfectly upright to avoid releasing liquid).

If cleaning becomes necessary, extreme care should be taken:

- Do not over wet the surface of the optical device
- Do not allow liquid to get into the filter housing (frame)

The following materials are recommended for cleaning:

- Dust blower, (e.g., Oriel Microfilter Duster #4905); or filtered dry nitrogen blown through an antistatic nozzle (e.g., Simco Inc., Hatfield, PA); or bulb type blower [must be very clean].
- Finger cots (e.g., Oriel #4907); polyethylene lab gloves.
- Porous cloth (e.g., Oriel #4908); cotton pads (e.g., Oriel #4910); cleans lens tissue; cotton swabs (avoid plastic stems which can dissolve in alcohol or acetone).
- Acetone (reagent grade) or alcohol. Alcohol should be 95% pure distilled ethl alcohol available from laboratory supply houses or local liquor store (190 proof). Do not use 100% pure or reagent grade which has the last 5% of water removed by absorbents (absorbents leave a residue).

Preferred Cleaning Procedure:

1. Blow off dust using clean, dry air.
2. If any contamination remains, twist tissue around a swab and wet it with alcohol (do not over wet).
3. With a circular motion gently wipe the periphery of the optical surface.
4. Repeat step 2 wiping the optic in one direction with a gentle figure-eight motion.
5. If some residue remains, repeat step 4 with acetone.

2. 3-6 MONTHS

Replace Vacuum Chuck Cover (P/N 0122-1580).

After removing the old cover, clean the aluminum chuck surface with solvent (e.g., Lactate Cleanup solvent #76820) to remove adhesive residue.

Before installing the new cover, apply two drops of adhesive (e.g., Loctite Instant Adhesive PRI SM 454) in opposite locations on the internal surface of the cover that will be in contact with the bottom surface of the aluminum chuck.

! CAUTION !

Do not allow adhesive to spread to the upper surface of the aluminum chuck.

When installing the cover, orient it so that a row of its holes will coincide with the diametrical groove of the aluminum chuck.

7 CALIBRATION/ADJUSTMENT PROCEDURES

7.1 CCD CALIBRATION

NOTE Calibration of the CCD is not a regular maintenance procedure. A special calibration wafer (P/N 0123-5552) is in any case required. Data from the calibration are stored in the battery-backup RAM.

1. USING HOST COMPUTER

- A. Place the calibration wafer (P/N 0123-5552) on the chuck. Calibration will not proceed unless the vacuum utility is present.
- B. Send the command 'P0CB' from the host computer. After entering this command, if the vacuum switch is set, the Prealigner will move the calibration wafer to the home position and will begin calibration of the CCD Sensor.
- C. Calibration is complete when the calibration wafer stops moving.

7.2 VACUUM SENSOR ADJUSTMENT

1. Turn on the vacuum switch, make sure that there is enough vacuum on the chuck (Ensure source vacuum is between 20-70 cmHg, 45cmHg optimum).
2. Place a wafer or calibration wafer (P/N 0123-5552) on the chuck.
3. To adjust the digital vacuum switch located on the right side panel: Depress the mode button once, use the up and down adjustment to set the low vacuum threshold to 20. Depress the mode button once more, use the up and down adjustment to set the high vacuum threshold to 70. Depress the mode button once more to return to operation mode.
4. Remove the calibration wafer from the chuck and verify that the red LED turns off.

***NOTE* There are software programs for IBM-PC compatibles to assist in the adjustment of the Prealigner. Contact Cybeq Systems for more information.**

8.0 TROUBLESHOOTING GUIDE

8.1 PREALIGNER TROUBLESHOOTING GUIDE

Problems/Symptoms	Cause	Action
No Power. Fan not operational. No power lamp indicator.	Burned out fuse. Bad power supply. Bad power cord.	Check AC power fuse. Test +5, +12, -12, and 24 volts DC on switching supply. Replace if bad. Verify AC at power cord.
No Prealigner motion after power up.	No +24 vdc to motor drive board.	Check 24 vdc and fuse on Motor Drive board.
Motor board time-out error.	Bad motor driver board or cable. X or Y Home limit switch bad.	Check/Replace Motor Drive board or cable (1). Replace X or Y Home limit switch.
Motor board communications error. Reset error.	Bad motor controller or motor driver power cable. Fuse and/or piggyback board.	Check/Replace cable. Check fuse on Motor Control board.
Vacuum chuck goes to home position and stops. Reset Error.	CPU board has suffered from an erasure of the NVRAM.	Place CPU in diagnostic mode and restore the XY reference position values.
Vacuum chuck goes to home position and stops. Lamp on CPU is not flashing.	CPU board has failed.	Replace or repair CPU board.
No motion in X or Y motors. No error reported.	X or Y-axis limit switch failure.	Replace failed switch.
Vacuum Failure	Vacuum leak. Vacuum sensor out of adjustment or bad.	Verify placement of vacuum tubing. Adjust or replace vacuum sensor.
CCD out of range.	Wafer not placed correctly on vacuum chuck. Illumination failure. CCD sensor failure. I/O board failure. Cable problem.	Check Wafer placement. Test CCD sensor-using tester provided by vender. Verify I/O Board voltage threshold. Check cables.
X, Y, Rotation, or AWS will not move.	Any one axis fails to move. Other axes are working. Motor drive component failure.	Verify operation of failed axis. Identify problem circuit on motor drive board.

8.2 ERROR MESSAGE BYTE INFORMATION TABLE

The following table defines each ASCII error value of the third byte of the Status word.

BYTE 3 VALUE	MEANING	ACTION
'0'	No Error	
'1'	CCD Measurement Error	<ul style="list-style-type: none"> - Bad CPU Board. - Bad Motor Controller Board. - Bad Video Processing Board.
'2'	CCD Out of Range	Failure in Measurement Circuitry: <ul style="list-style-type: none"> - Wafer misalignment too large, reposition wafer. - Optics Path Dirty, clean according to 6.2. - Cables Disconnected. - Light source burned Out. - Bad I/O Board. - CCD Sensor not adjusted properly. - NVS-Ram fault, Re-calibrate.
'3'	Displacement >0.35 inch	<ul style="list-style-type: none"> - Wafer Misalignment too large, reposition wafer.
'4'	Limit Switch Error	<ul style="list-style-type: none"> - Check Limit Switches "P0TI" command.
'5'	Motor Board Time-Out	<ul style="list-style-type: none"> - This error message can not occur on Prealigner.
'6'	Motor Board Comm. Error	<ul style="list-style-type: none"> - Motor controller board faulty or not present.
'7'	Notch/Flat Not Found	<ul style="list-style-type: none"> - Use "P0IM" Command to check if set to correct Notch/Flat mode. - Dirty Optics or Cracked / Damaged Wafer.
'8'	Vacuum Sensor Error	Vacuum Sensor is not turning off: <ul style="list-style-type: none"> - Mis-adjusted Vacuum Sensor. - Bad Vacuum Solenoid.
'9'	Vacuum Supply Failure	Vacuum sensor is not turning off: <ul style="list-style-type: none"> - Mis-adjusted Vacuum Sensor. - Bad Sensor Wiring.
'A'	Reset Not Performed	<ul style="list-style-type: none"> - Check Limit Switches with "P0TI" command. - Retry Reset with "P0RS". - Cables not connected - Motor Driver board failure.
'B'	NVS-RAM Data Mismatch	<ul style="list-style-type: none"> - Re-calibrate Prealigner
'C'	No Error	<ul style="list-style-type: none"> - Command sent with bad parameter, correct and re-send.
'D'	Bad Calibration Data	<ul style="list-style-type: none"> - Re-calibrate Prealigner. - Not enough active pixels, readjust lamp on CPU board, then re-calibrate.

9 STANDARD PREALIGNER DRAWINGS

9.1 PER4MER 3000 PREALIGNER OUTLINE

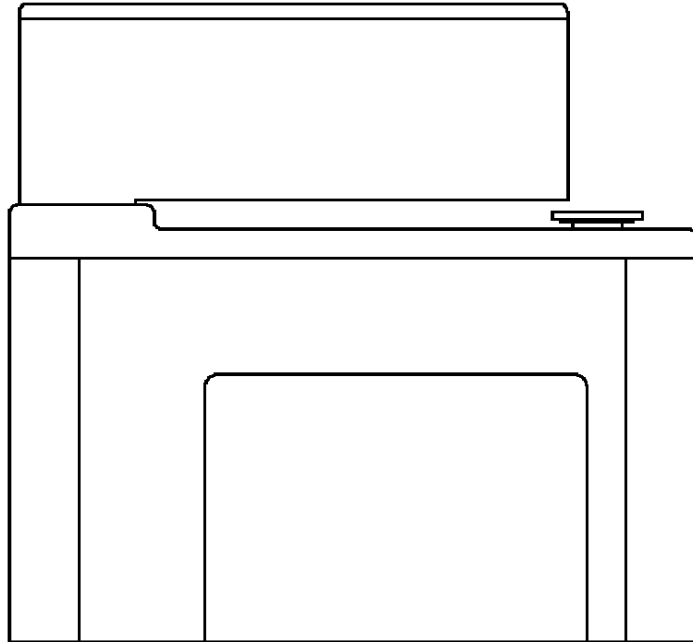

SIDE VIEW

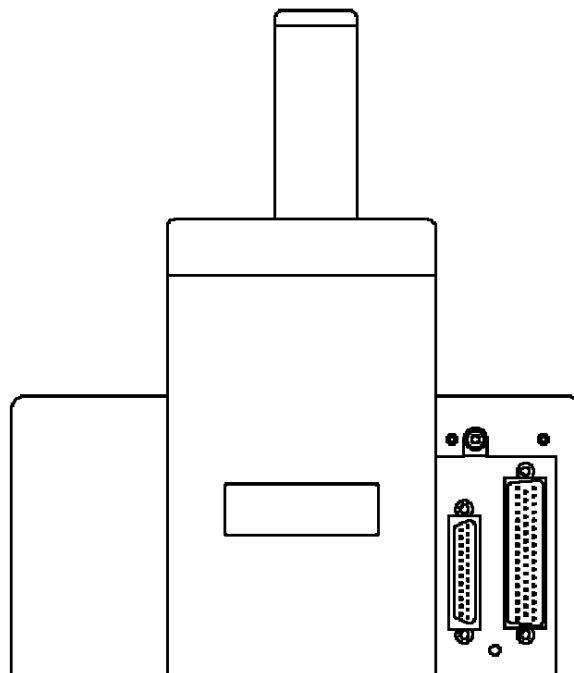

REAR VIEW

9.2 PER4MER 3000 HALF RACK CONTROLLER

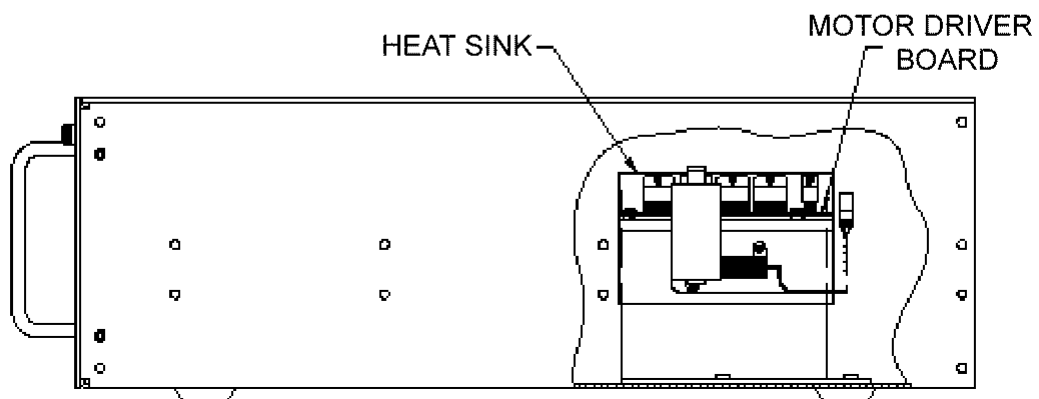
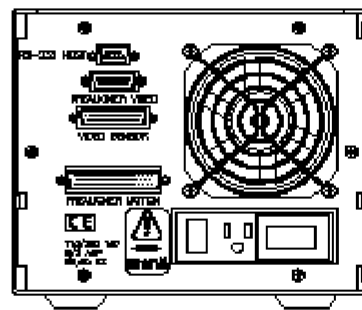
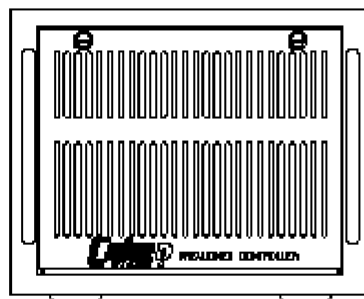
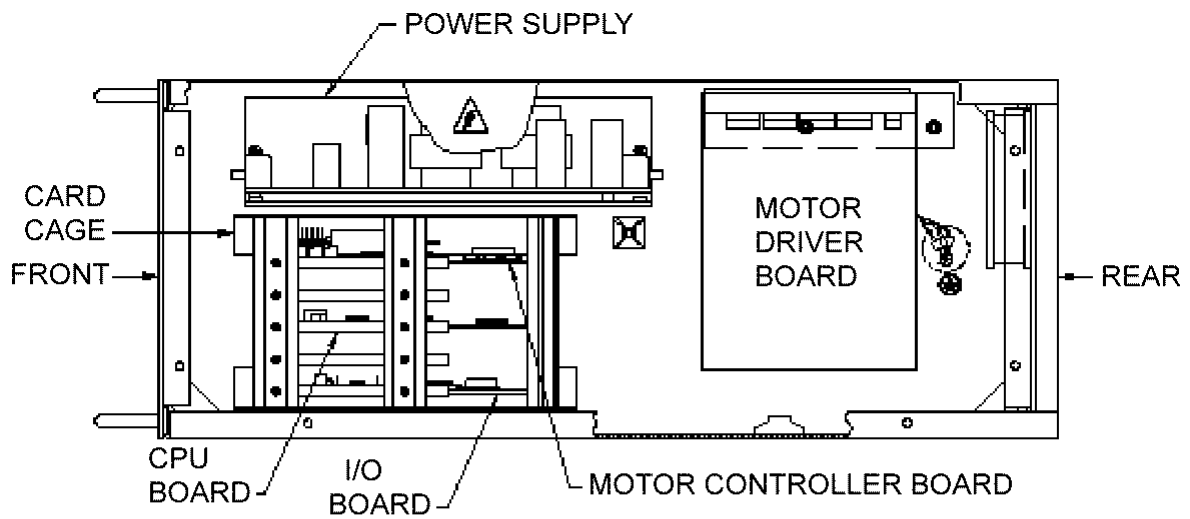

CONTROLLER ASSEMBLY

9.3 PER4MER 3000 HALF RACK CONTROLLER WIRING DIAGRAM

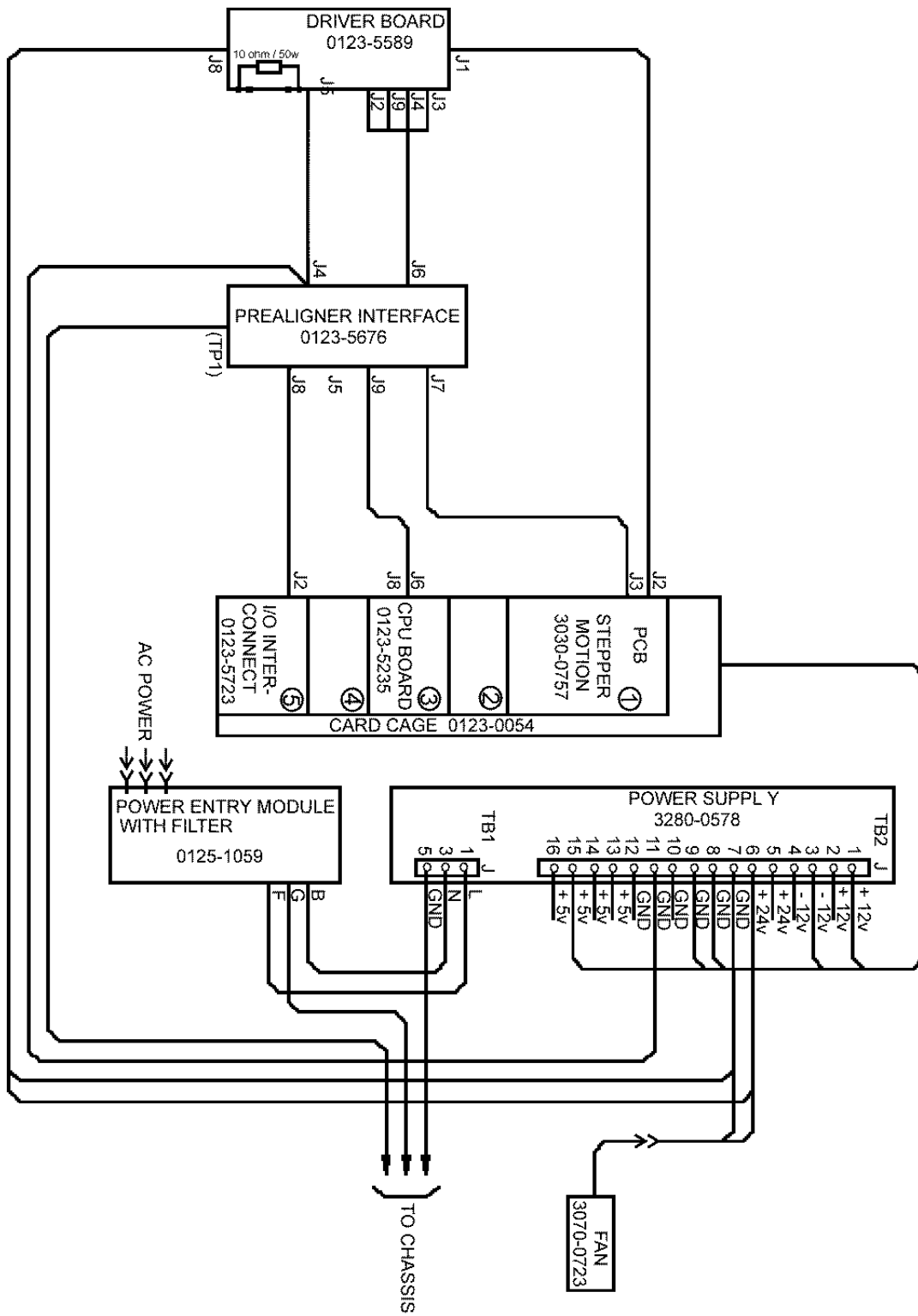

WIRING DIAGRAM

