

**Ludl Electronic Products Ltd.
Stage Service & Troubleshooting
Manual**

90M024



LUDL ELECTRONIC PRODUCTS, LTD.

171 BRADY AVENUE
HAWTHORNE, NY 10532
Tel: (914) 769-6111
Fax: (914) 769-4759

Table of Contents

<i>Preface</i>	3
<i>Preventive Maintenance</i>	4
Lubrication Procedure.....	4
<i>Field Repairs</i>	5
Limit Switch Failure.....	5
Limit Switch Activation.....	6
Rotary Encoder Failure.....	7
Motor Problems.....	9
Stepper Motors.....	9
DC Motors.....	11
<i>Troubleshooting Guide</i>	12

Preface

Most LEP stages are driven by a conventional motor which turns a leadscrew thereby translating the motor rotation into linear motion. The motor, either stepper or DC servo, is coupled to the leadscrew shaft directly without any mechanical reduction. All stages ride on precision-ground cross roller guide bearings.

LEP XY stages are carefully designed and assembled for high accuracy and performance. Although the stage will retain its performance characteristics for many years with minimal maintenance, LEP highly recommends regular preventive maintenance service to ensure the stage's performance. This guide outlines proper preventive maintenance and recommended service and troubleshooting procedures.

This instruction is for the service and maintenance of LEP stages. It is intended to serve as a reference for personnel who are trained in the service and repair of stages. All LEP products are warranted for one (1) year from the date of purchase. LEP assumes no responsibility for damage to units occurring from improper service or being adjusted contrary to these instructions. These units will not be covered by this warranty.

The following procedures are designed to be performed by a qualified service technician. This document is intended as a guide and does not provide the detail necessary for a novice to make repairs.

Before beginning take note that:

- All screws and hardware are metric, you will need a set of metric Allen wrenches, specifically 1.27, 1.5, 2.0, 2.5 3.0, 4.0 and 5.0 mm.
- All lubrication should be done with LEP specified grease, P/N: 61-ME00092 for the leadscrews and P/N: 61-ME00093 for the linear bearings.
- Always disconnect the power to the system before dismantling any component to avoid shorts and possible component damage.
- Anyone working inside the stage should be properly grounded to prevent damage to components through electrostatic discharge. Proper "ESD" precautions should always be used when working on any LEP product.

Preventive Maintenance

Normally the leadscrews and guides should be cleaned and re-lubricated every year to maintain nominal performance. Heavy use, such as semiconductor wafer inspection, requires more frequent maintenance after 1000 hours of use. The specified grease is LEP part number 61-ME00092 for the leadscrews and 61-ME00093 for the linear guide bearings. These greases are stable synthetic greases suitable for clean-room applications.

Lubrication Procedure:

It may be necessary to dismount the stage from the microscope. Remove the leadscrew covers from stage which are held on by four M3 or M4 button head screws. Take note of the orientation of the button head screws and to their locations. These four screws will usually be of varying lengths. Bearing rails and leadscrews can now be cleaned and lubricated according to the following procedure:

1. Use a lint-free cloth to clean the old grease from the bearing rail or leadscrew. It may be helpful to use a Q-tip to clean the rails, sometimes this enables you to reach deeper into rails and further into the stage since not all of a rail will usually be exposed. Even then, you should only clean as much of the rail as possible. Afterwards, check that there are no cotton strands left behind. Do NOT use a Q-tip on the leadscrews because cotton strands may get into the leadscrew nut. *Note if there are any fine metal shavings in the old grease, this could be a sign of potential failure.
2. Apply a thin coat of grease to the entire length of the bearing or leadscrew. Make sure that you get grease into the leadscrew grooves. Use only P/N: 61-ME00092 grease for the leadscrews and P/N: 61-ME00093 for all other bearings.
3. Run the bearing or leadscrew back and forth a few times to work the fresh grease into the mechanism. It may be helpful to use the joystick to move the axis under power especially on a stage with a 1mm pitch leadscrew where it is not effortless to manually move the stage.
4. Using the cloth, remove the grease again and re-lubricate as in step 2. If the removed grease was not clean and/or continuously showed signs of particulate contamination repeat from step 2 as many times as necessary. Three to five repetitions will usually be sufficient to properly purge the grease from inside the leadscrew nut and rails.
5. Replace the leadscrew covers returning each button head screw to the exact location from where it was removed.

*If metal shavings were present note it in the service record. This could be an indication that the bearing or leadscrew may need to be replaced in the near future.

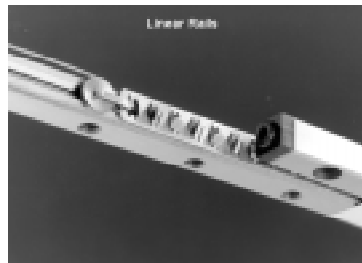
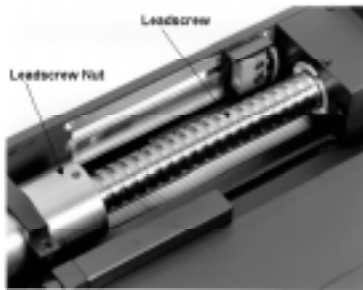

Field Repairs

Limit Switch Failure:

The most common failure of a Limit Switch is where the plunger is either intermittently sticking or is permanently stuck in the switch body. This problem could be demonstrated by the ability of the stage to move in one direction but not in the reverse. It is typically caused by mishandling or running into the limit at very high speed. An easy way to diagnose this type of failure is to check the limit switch state on the front of the MAC 2000 or MAC2002 controller by observing the status of the LED's on the 73000503, 73002050, or 73002051 motor driver modules, most notably, a limit switch indicator LED would remain on. It may be possible to fix this type of problem by pressing the switch plunger with a flat blade screwdriver. Sometimes this will "free" the plunger. If that does not fix the problem, the switch will have to be replaced. There is only one type of switch used in the stages designated by the LEP P/N: 52-1SX1-T. The switches are held in place by two M2X6 flat head screws (P/N: 78-D965-M2X6) and the wires are soldered to the switch pins. Just replace the "bad" switch and remember to keep the orientation of the wires.

LEP Part numbers:

- 52-1SX1-T, limit switch
- 78-D965-M2X6, M2X6 flat head screws

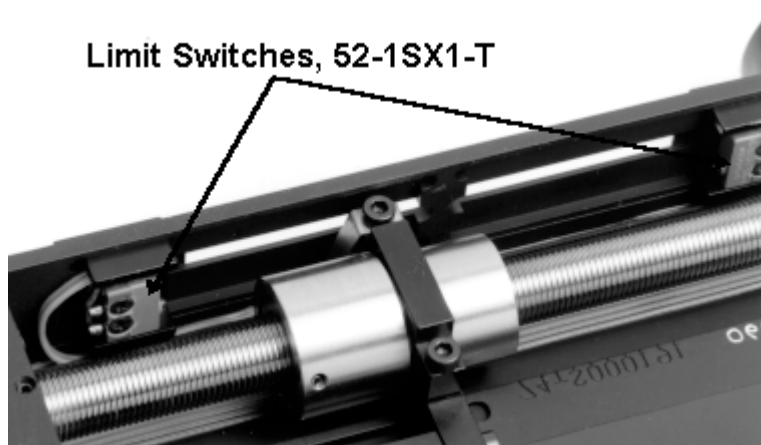

Limit Switch Activation:

The limit switch spring is the mechanism that triggers a limit switch at contact on most LEP stages. It is mounted to the leadscrew nut clamp with a single socket head screw. If the stage exhibits a problem in limit switch triggering, such as repeated slamming into the hard stop before switch activation, many times it will be this spring slowly bending away from the plunger over time. This problem can be rectified by taking a flat blade screw driver and gently bending the spring back out towards the limit switch. This will activate the switch faster by reducing over travel.

LEP part numbers:

- 74-S900023, limit switch spring

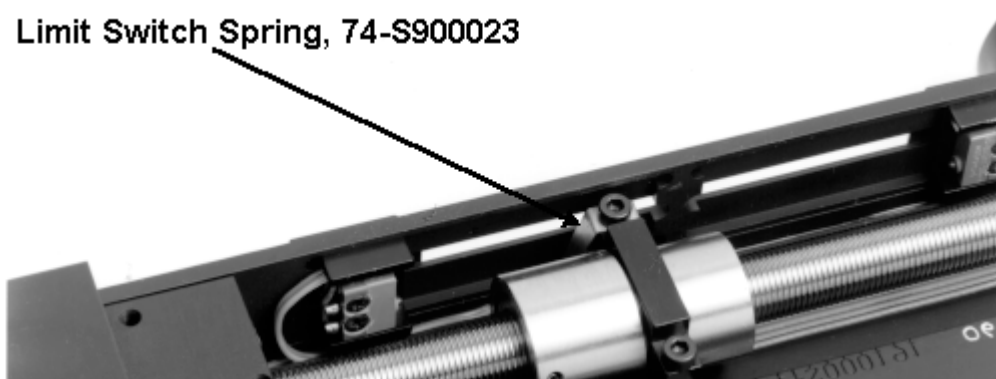

Rotary Encoder Failure:

Note that before attempting these procedures you **MUST** be properly grounded due to the encoders extreme sensitivity to electrostatic discharge.

Typically LEP upright stages use rotary encoders to generate positional feedback to the controller. Normally an encoder failure involves losing all positional feedback from the affected axis. However, other problems can present themselves in the same manner and should be ruled out before replacing the encoder. A break in the encoder connection wiring, either internal or external, can appear as the same as an encoder failure. In fact, most cases of loss of encoder feedback are the result of a worn out flex cable causing a short in the encoder lines. Unfortunately, flex cable replacement must be done at the factory because of the complexity of its procedure. The use of an Oscilloscope or even a simple Multimeter can be useful in troubleshooting the wiring harness and cabling. It may also be useful to attempt to operate the controller in open loop configuration (non-encoder mode.) Since a stepper motor stage with encoders should always work in both open loop and closed loop configuration, this can tell you if other functions of the stage are operating correctly in an attempt to narrow the problem down to the encoder. Consult the controller's Configuration Manual before changing any configuration.

After troubleshooting the problem down to encoder failure it may now be necessary to replace the encoder. Typically the encoders are mounted on the end of the leadscrew shaft at the opposite end of the motor.

1. There is a cylindrical cover over the encoder which is threaded onto the encoder base plate. The cover can be removed by turning it counterclockwise until it is completely unscrewed.
2. Take note of the wire connections on the four position header strip from the stage into the encoder's four position MTE connector. Unplug the header strip from the MTE connector.
3. The encoder is mounted to the leadscrew shaft with two M3X10 set screws which can be accessed through the encoder base plate. Before loosening the set screws take note that there is also an alignment pin from the encoder into a slot of the encoder base plate. This pin has a small spring pushing against it and the internal wall of the encoder base plate. Loosen the two set screws and gently pull the encoder off of the leadscrew shaft while being careful not to lose the spring.
4. Note the pin's orientation, remove it, then install it into the new encoder keeping the same orientation.
5. Slide the new encoder onto the leadscrew shaft lining the pin into the encoder base plate slot against the spring.
6. Mount the encoder as perpendicular to the shaft as possible by using two small shims (0.3 mm thick) in between the encoder and the encoder base plate. This will ensure proper and equal spacing. Now tighten the set screws then remove the shims. If the encoder is not perpendicular to the shaft, as the stage moves the encoder will wobble an excessive amount causing the possibility of severed wires and/or a distinct noise as the encoder repeatedly bangs against the inside of the encoder cover.
7. Reconnect the wires with their original orientation. Note that the MTE connector has a small arrow to designated pin 1. The wiring should be as follows:

Pin Number	Encoder Wire Color (MTE Connector)	Stage Wire Color (Header Strip)
1	Blue	Brown
2	White	Red
3	Black	Orange
4	Red	Yellow

8. Apply a thin strip of non-conductive tape to neatly hold the wires down over the encoder flat portion.
9. Gently install the encoder cover.

LEP Part Numbers:

- 86-1256-001, rotary encoder
- 78-D427-M3X10, pin partial thread set screw
- 61-ME00079, spring
- 66-EL00009, 50 position header strip. It can be cut to size.

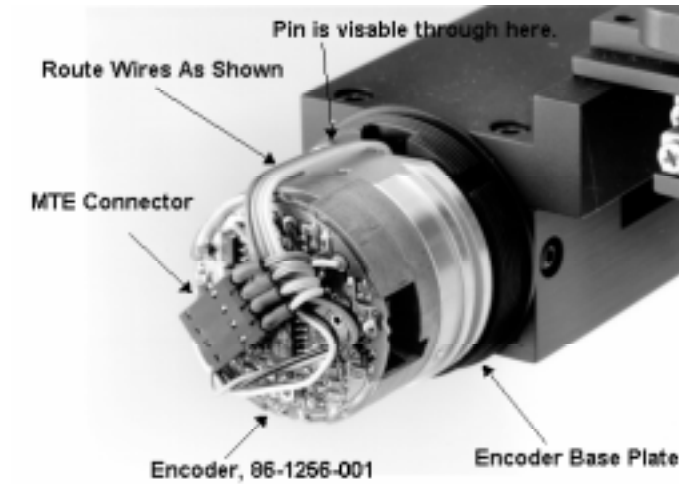

Motor Problems:

Performance wise, the stage axis motors are extremely durable and consistent. Therefore, any time an electrical or performance problem occurs all other components should be analyzed thoroughly before concluding that the problem lies inside the motor. Usually, the only time a motor would have to be changed is because of physical destruction. This can happen from shipping damage or by mishandling, such as dropping or something banging into the stage in which the result would be a bent motor shaft. Take note that a severe jolt may knock the stage out of alignment. In these cases the stage should be sent back to the factory to be properly checked out and adjusted. Stage alignments are not serviceable in the field. Otherwise, if the stage exhibits problems such as repeated stalling and/or a strange noise that seems to be coming from the motor, the motor should be changed only after complete troubleshooting leads only to the motor. In other words, all cables, flex cables, encoders, rails, leadscrews, and alignments should be ruled out.

Stepper Motors

There are only two kinds of stepper motors used on LEP high end stages, part numbers 84-ZSS422001.2 and 84-6000-001. They can be distinguished by their physical characteristics as shown below.

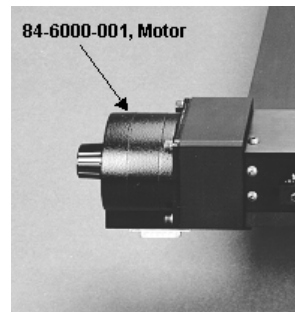
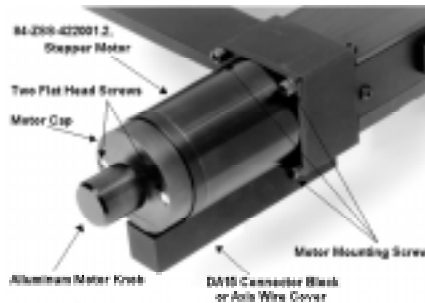

Procedure:

1. Loosen the coupling in between the motor shaft and leadscrew with a 1.5mm hex Allen wrench. In some stages there is an access hole to get to the coupling but in most cases you will have to remove either the connector mount or the wire cover from the X or Y connector blocks to gain access. If you have to remove the connector mount, be extremely careful with the DA15 connector. There should be enough slack in the wires of the DA15 connector to pull the connector mount out of the way. In other words, you can leave the DA15 connector in the connector mount in order to complete this procedure.



2. Once the motor shaft is free you can then remove the motor knob. Older LEP stages have a plastic motor knob that can be removed by prying off the end cap and loosening the nut with a 10mm nut driver. Newer LEP models use an aluminum knob held on by one M3 set screw that clamps the knob onto the motor shaft that can be accessed through the side of the knob. When loosening the set screw, take note that there is a small piece of nylon rod in between the set screw and the motor shaft. Be careful not to lose this piece when removing the knob. Without the nylon, the set screw will push into the motor shaft, contorting the metal, making it extremely difficult to remove the motor knob at a later date.

3. If you have an 84-ZSS422001.2 motor, remove the two flat head screws that hold on the motor cover, then pull the motor cover off of the top of the motor.
4. Notice that there are two sets of wire groups connecting to the 84-ZSS422001.2 motor. One set from inside the motor and the other from the ribbon cable within the stage. Take note of each wire connection then unsolder the wires coming from the ribbon cable.
5. Remove the four screws and lock washers that hold the motor onto the stage and gently pull the motor out of the axis. Note that if you have an 84-6000-001 motor the wires should still be connected to the DA15 connector. Unsolder the motor wires.
6. Install the new motor into the flex coupling to the leadscrew and tighten. The end of the flex coupling should be very close to the motor end but not touching, about 0.65mm, or approximately the thickness of seven sheets of paper.
7. If you have an 84-ZSS422001.2, remove the motor cover from the new motor and check that the wiring coming from within the new motor matches that of the old motor. The wires from inside the motor should connect to the motor pins with 24 gauge jumper wire between the pins as follows:

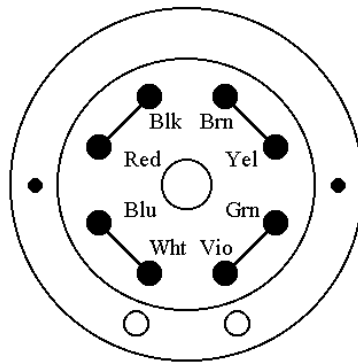

MOTOR REAR VIEW
WITH COVER REMOVED.

Once you have determined that the motor wires are correct, you can solder on the stage ribbon cable to the motor pins as follows:

Stage Ribbon Cable Color	Motor Wire Colors
Orange	Blue/White
Brown	Black/Red
Red	Brown/Yellow
Yellow	Green/Violet

8. Install the motor cover with the two flat head screws.
9. If you have an 84-6000-001, the motor wires should be soldered directly to the DA15 as shown below:

Motor Wire Color	DA15 Connector Pin
Red	10
Black	No Connection
Red/White	12
Green	13
White	No Connection
Green/White	15

10. Install either the connector mount or wire cover from step 1 if necessary.
11. Install the motor knob with protective nylon rod in between the set screw and the motor shaft. Note that the motor knob should be mounted about 1mm from the top of the motor cover.

LEP Part Numbers:

- 74-S900080, aluminum motor knob
- 84-ZSS-422001.2, stepper motor
- 74-C05mm-C05mm, flex shaft coupling, 5mm to 5mm (for 84-ZSS-422001.2, motors)
- 84-6000-001, long travel stage motor used in 12"x12", 16"x16", 20"x20"...ext.
- 74-WAC15-8-5MM, flex shaft coupling, ¼" to 5mm (for 84-6000-001, motors)

DC Motors

DC Motors can be removed exactly like the stepper motors using the same procedure detailed above. The main difference is that you will be removing a motor assembly. In other words, the motor is mounted to the motor flange, the motor cover is mounted to the motor, and the motor flange is mounted to the stage. To change a DC motor, first remove the motor assembly then take the motor assembly apart to get to the motor. The motor cover is mounted to the motor with two M3X3 flat point set screws, and the motor is mounted to the flange with eight M2X6 cheese head screws. Wires go through the flange and along the inside of the motor cover connecting to two terminals. The orange wire is soldered to the positive (+) terminal and the red wire is soldered to the negative (-) terminal.

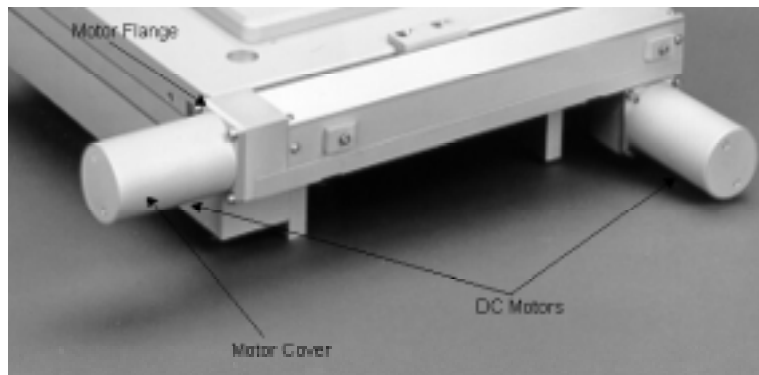

LEP Part numbers:

- 84-3557K020CS, DC motor
- 74-S920056, clear anodized "3557K020CS" motor cover
- 74-S900056, black anodized "3557K020CS" motor cover
- 84-3540K015C, DC motor
- 74-S900051, black anodized "3540K015C" motor cover

Troubleshooting Guide

SYMPTOM	POSSIBLE CAUSE	SOLUTION
<p><i>Limit switch failure:</i></p> <p>An axis hits a hard stop before activating a Limit Switch.</p> <p>Limit switch is always or intermittently activated.</p>	<p>The limit switch plunger is not being activated.</p> <p>The limit switch plunger is stuck in the switch body.</p> <p>Limit switch may have been wired backwards when replaced.</p>	<p>Bend the limit switch spring towards the plunger so that the switch is activated before a hard stop is hit.</p> <p>Try to release the switch with a flat blade screw driver. If this does rectify the problem then replace the switch.</p> <p>All stage limit switches are wired in the normally open position.</p>
<p><i>Axis failure:</i></p> <p>Stage axis will consistently stall.</p>	<p>After greasing an axis, if there is too much grease left on the leadscrew, the motor will stall.</p> <p>Electrical failure.</p> <p>Defective encoder.</p> <p>Defective motor.</p> <p>Alignment problems.</p>	<p>Wipe leadscrew clean then grease again. There should just be enough grease to lightly cover the leadscrew. No thick blotches.</p> <p>Check for any breaks in encoder wiring or axis flex cables. A flex cable must be repaired by LEP.</p> <p>See page 7.</p> <p>See page 8.</p> <p>Send the stage back to LEP</p>